

the Breville Precision Brewer™ Thermal

Instruction Book - BDC455



Breville



Contents

- 2 Breville Recommends Safety First
- 6 Components
- 8 Features
- 8 Assembly
- 9 Operation
- 13 Programming
- 14 Tips
- 17 Care & Cleaning
- 18 Troubleshooting

BREVILLE RECOMMENDS SAFETY FIRST

At Breville we are very safety conscious. We design and manufacture consumer products with the safety of you, our valued customer, foremost in mind. In addition we ask that you exercise a degree of care when using any electrical appliance and adhere to the following precautions.

IMPORTANT SAFEGUARDS

READ ALL INSTRUCTIONS BEFORE USE AND SAVE FOR FUTURE REFERENCE

- Carefully read all instructions before operating and save for future reference.
- Remove any packaging material and promotional labels or stickers before using the Breville Precision Brewer for the first time.
- To eliminate a choking hazard for young children, remove and safely discard the protective cover fitted to the power plug of this appliance.
- Do not place the product near the edge of a bench or table during operation. Ensure the surface is level, clean and free of water and other substances.
- Do not let the cord hang over the edge of a bench or table, or become knotted. Keep away from hot gas or electric burner, or where it could touch a heated oven.

- This appliance can be used by children aged from 8 years and above if they have been given supervision or instruction concerning use of the appliance in a safe way and understand the hazards involved. Cleaning and user maintenance shall not be made by children unless they are aged from 8 years and above and supervised. Keep the appliance and its cord out of reach of children aged less than 8 years.
- Appliances can be used by persons with reduced physical, sensory or mental capabilities or lack of experience and knowledge if they have been given supervision or instruction concerning use of the appliance in a safe way and understand the hazards involved.
- Children shall not play with the appliance.
- Keep the appliance and its cord out of reach of children aged less than 8 years. Cleaning and user maintenance shall not be made by children without supervision.
- Regularly inspect the supply cord, plug and actual appliance for any damage. If found damaged in any way, immediately cease use of the appliance and return the entire appliance to the nearest authorised Breville Service Centre for examination, replacement or repair.
- Keep the appliance and accessories clean. Follow the cleaning instructions provided in this book. Any procedure not listed in this instruction booklet should be performed at an authorised Breville Service Centre.
- The installation of a residual current device (safety switch) is recommended to provide additional safety protection when using electrical appliances. It is advisable that a safety switch with a rated residual operating current not exceeding 30mA be installed in the electrical circuit supplying the appliance. See your electrician for professional advice.
- **Misuse may cause injury.**

SPECIFIC INSTRUCTIONS FOR BDC450/455

- This appliance is recommended for household use only. Do not use this appliance for any purpose other than its intended use. Do not use in moving vehicles or boats. Do not use outdoors.
- If the appliance is to be:
 - left unattended
 - cleaned
 - moved
 - assembled; or
 - stored
- Ensure the product is properly assembled before first use.
- Do not operate the appliance without water in the water tank. Use only cold, preferably filtered water. Do not fill the appliance with any other liquids for brewing operations.
- Ensure the supplied mesh basket filter or a paper filter (8-12 cup, flat base basket style with ~ 8.25cm base) is placed in the coffee basket before using the appliance. Do not use the mesh basket filter in conjunction with a paper filter.
- Before starting a brew cycle:
 - Check that the carafe drip stop moves up and down freely.
 - Completely empty the carafe and securely lock the carafe lid in place.
 - Insert and seat the carafe under the drip stop.
 - Ensure the filter basket is empty and properly fit in place.
- During a brew cycle:
 - Do not remove the carafe or remove the filter basket while the unit is in a brew cycle. Failure to follow the above may lead to scalding or serious injury.
- Some surfaces may be hot, use caution when touching or lifting the unit or accessories.
- Use only carafe handle when lifting the carafe. The carafe is designed for use with this appliance only. It must never be used on a range top or in a microwave.
- Scalding may occur if the carafe lid or basket is removed during the brewing cycle.

CAUTION

- Risk of injury. Proper installation/removal of basket is required to reduce the risk of splashing of hot water.
- Always ensure the carafe lid is securely locked in place onto the carafe before pouring.
- Do not use the carafe with a cracked, loose, weakened or damaged handle.
- Do not use the filter basket with a cracked, loose, weakened or damaged handle.
- Do not touch hot surfaces. Use the handle for lifting and carrying the carafe.
- Always wait until the machine has cooled before removing the brew basket.
- Do not set a hot carafe on a wet, cold or heat sensitive surface.
- Do not use harsh or abrasive materials when cleaning any part of this appliance such as steel wool or scoring pads.
- Always switch the appliance off by removing the power plug from the power outlet before attempting to move the appliance, when the appliance is not in use and before cleaning and storing. Allow to cool before putting on or taking off parts, and before cleaning the appliance.
- The use of attachments not sold or recommended by Breville may cause fire, electric shock or injuries.
- Proper installation of filter basket, showerhead seal, and showerhead locking ring is required to reduce the risk of splashing of hot water.
- To prevent damage to the appliance do not use alkaline cleaning agents when cleaning, use a soft cloth and a mild detergent.
- Heating element surface is subject to residual heat after use.
- The appliance shall not be placed in a cabinet when in use.

**FOR HOUSEHOLD USE ONLY
SAVE THESE INSTRUCTIONS**

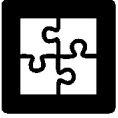

Components

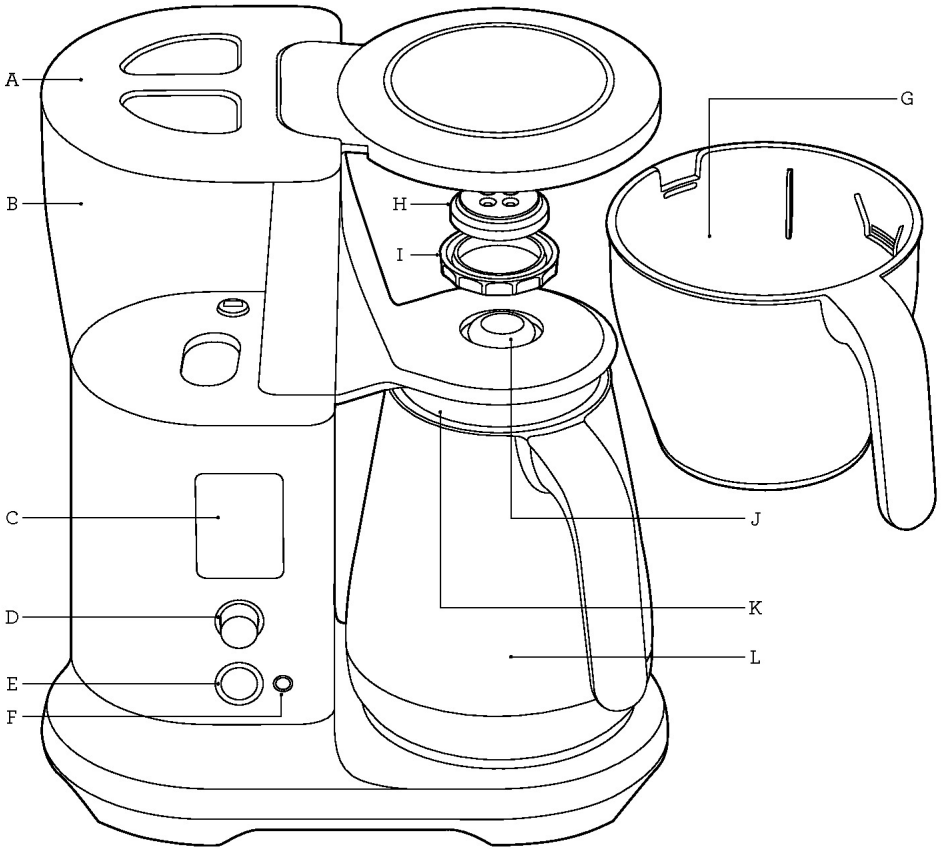

- A. Tank lid
- B. Water tank
- C. LCD display
- D. SELECT dial
- E. START|CANCEL button
- F. AUTO START button

- G. Brew basket
- H. Showerhead
- I. Showerhead ring
- J. Drip stop lever
- K. Carafe lid
- L. Carafe

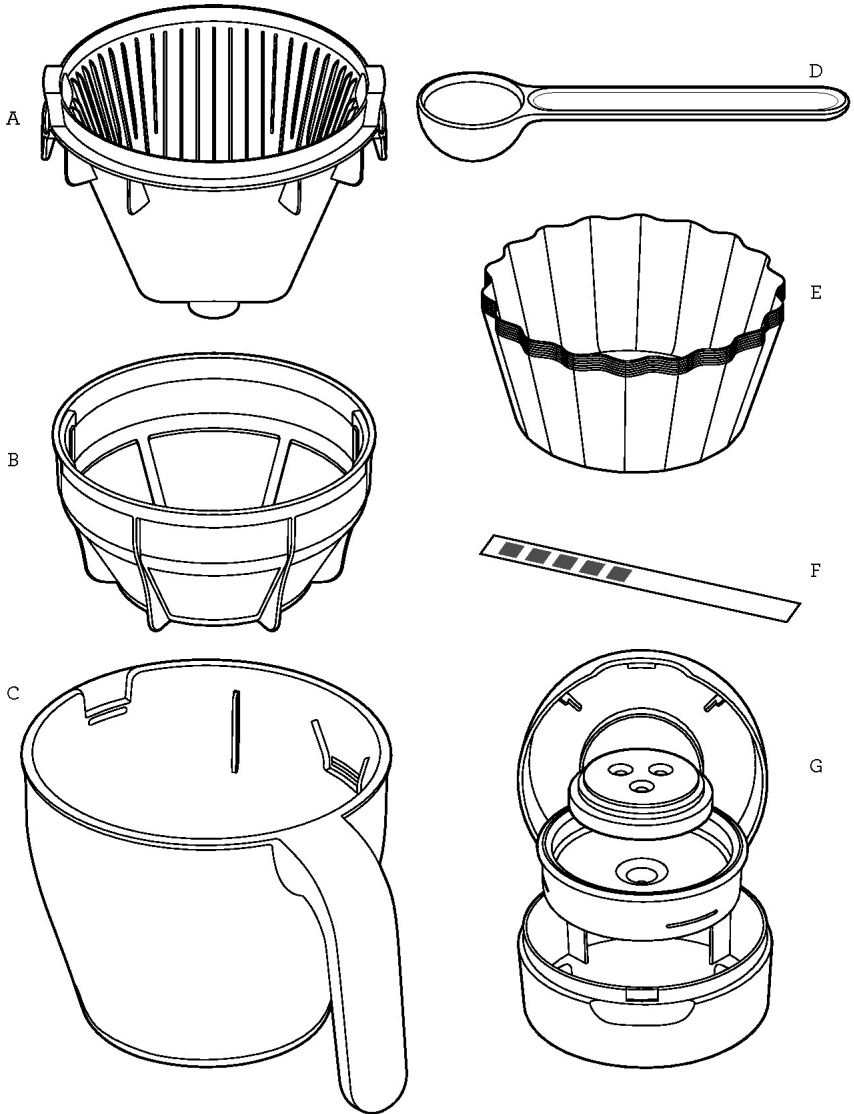

ACCESSORIES

- A. Cone filter basket insert
- B. Mesh basket filter
- C. Brew basket
- D. Breville coffee measuring scoop
- E. Flat bottom basket filter paper pack (10 pieces)
- F. Water hardness test strip (see page 9 for directions)
- G. Pour over adapter kit



Features

Your Breville Precision Brewer has been designed to make coffee of the highest quality, just the way you like it, no matter what style of coffee you enjoy.

Fast: Brew up to 12 cups (1.8L) as fast as the brewer can deliver the water in the tank.

Gold: This mode has been certified by the SCA (Specialty Coffee Association) to meet their rigorous technical requirements using the Cone Filter Basket and water volumes of 1.0L & 1.2L together with a brew ratio of 55g of coffee to 1.0L of water.

Strong: Brew settings are automatically adjusted so you get a stronger cup of coffee.

Tip: for strong coffee, increase the amount of ground coffee you normally use.

Over Ice: Brew up to 4 cups (600ml) of stronger coffee that tastes great when poured over ice and garnished any way you like.

MyBrew: Brew up to 12 cups (1.8L) having total control over all the variables, brew water temperature, bloom time, water delivery speed, so you get coffee just the way you like it.

Cold Brew: Brew up to 600ml of Cold Brew coffee with the flexibility to adjust steeping time between 0-24 hours and have the coffee automatically delivered into your favorite vessel.



Assembly

BEFORE FIRST USE

Unpack all parts and accessories before removing and safely discarding all packaging material and promotional labels. Ensure the power cord is unplugged from the power outlet.

Wipe the exterior stainless steel housing with a soft, damp cloth. Wash the lid, brew basket, cone filter insert, mesh basket filter, and carafe in warm, soapy water and a soft cloth. Do not use abrasive cleansers, pads or cloths which can scratch the surface. Rinse and dry thoroughly. Press carafe drip stop ensuring it can freely move up and down.

WATER HARDNESS SETTING

When first turned on, the machine will show 'Hard' on LCD, asking you water hardness level. Press SELECT dial once. Dip the water hardness test strip into the filled water tank for 1 second, remove and wait for 1 minute to reveal the result. Rotate SELECT dial and press the dial to select the level according to the number of dots shown on the strip. To reset water hardness, please refer to FACTORY RESET (page 17).

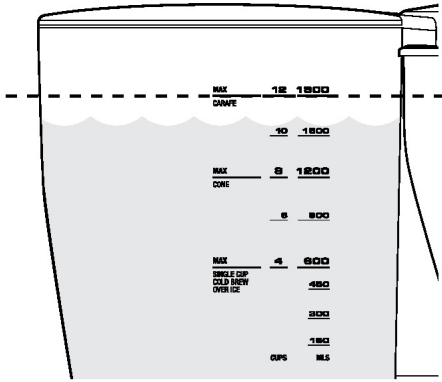

NOTE

This machine will brew all the water in the tank. Ensure the tank does not contain an excess amount of water.

4. For the very best tasting coffee, we recommend using freshly roasted whole bean coffee and grind with a burr grinder directly before you brew. The grind should be medium/coarse, never use coffee ground for espresso as your coffee basket may overflow.
5. Grind enough coffee beans for the volume you're making. For a full 1.8L carafe, we recommend 99g of coffee, approximately 12 level Breville measuring scoops. Roughly 1 scoop for every 150ml. Refer coffee/water ratio chart on page 14.
6. Insert the correct filter paper, cone or flat bottom, or mesh basket, into the brew basket, then, add your ground coffee. Insert the brew basket into the machine.

NOTE

Never use both mesh basket filter and paper filter at the same time.

NOTE

Coffee with superior taste & clarity will come from using a paper filter.

NOTE

The mesh basket filter will allow some fine coffee grounds to brew into the coffee. This will appear as sediment in the cup or carafe. This is normal. Only use the mesh basket filter provided as others may cause the machine to overflow.

7. Lock the carafe lid and place the carafe under the drip stop outlet.

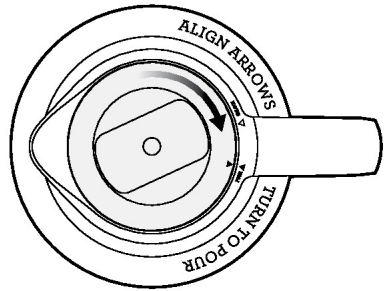

CAUTION

The carafe **MUST** be in place before you brew with water level higher than 'SINGLE CUP' line. Otherwise the coffee basket will overflow.

NOTE

Always ensure your carafe is clean and empty before brewing. Residual coffee will affect the taste and liquid in the carafe will cause it to overflow.

NOTE

Always ensure your carafe is **EMPTY** before brewing to prevent overflow.

8. Rotate the SELECT dial to the desired mode. Press the START|CANCEL button. The machine will display the progress:
 - The machine will remind you to insert either cup or carafe where applicable
 - Heating: the heating system is being pre-heated to the optimal temperature
 - Blooming: the bloom phase of preparation is in progress
 - Brewing: brew water at the correct/ selected temperature is being delivered to the ground coffee
9. When your coffee is ready, the machine will beep 3 times. The machine will display the “Time since brewed”.



NOTE

Never fill the water tank once the coffee machine has started a brewing cycle.

BREW MODES

- **FAST:** This mode is to deliver the fastest brewed coffee. This coffee machine is one of the fastest 12 cup (1.8L) brewers.
- **GOLD (recommended):** This mode meets the SCA (Specialty Coffee Association)’s rigorous technical requirements using the cone filter basket.
- **STRONG:** This brewing mode delivers a stronger tasting coffee.
- **MY BREW:** Allows you to customize every brew setting.

- **Bloom Time:** Coffee bloom occurs when hot water hits the ground coffee. This setting allows you to adjust how long the bloom time lasts. We recommend 30-60 seconds. During this time the brewing cycle pauses to allow coffee to naturally bloom. See ‘TIPS’ for more about Bloom Time.
- **Brewing Temp:** You can adjust the temperature of the brew water being delivered to the ground coffee to suit your favorite coffee. See “TIPS” for more about setting brew water temperature.
- **Flow Rate:** You can adjust brewing time to control contact time by adjusting the water delivery speed. Choose between Slow, Medium, and Fast (default).
- **Pour Over:** If you are using the Pour Over Adapter, this must be turned on.
- **OVER ICE:** This is to make stronger coffee for ice coffee.
 - Fill the water tank with the amount of water you want to brew up to 600ml line and start brewing. After brewing, pour over ice. See ‘TIPS’ for details.
- **COLD BREW:** Cold Brew coffee is brewed differently to traditional coffee. It uses cold, not hot water. Your brewer uses the “Full Immersion” method of brewing cold brew which steeps the water and coffee together over an extended duration – typically between 4 - 14 hours. This method creates an intense smooth coffee with little bitterness. Brew ratios are also different, and much higher than normal. Breville recommends a brew ratio 2-3 times higher than average, approximately 3 Breville scoops to every 150ml of water.
 - See ‘TIPS’ for step-by-step guide of brewing Cold Brew.
 - Brew time is adjustable.



NOTE

OVER ICE mode and COLD BREW mode will be disabled if there is more than 600ml of water in the tank.

SINGLE CUP/SMALLER VOLUMES (LESS THAN 4 CUPS, 600ML)

1. Your Breville Precision Brewer will recognize when the brewer has less than 4 cups (600ml) of water & will adjust the brew settings, automatically, to make the best possible tasting coffee. Fill your cup with fresh cold water and then pour it into the water tank, ensuring the water level stays below the SINGLE CUP line.

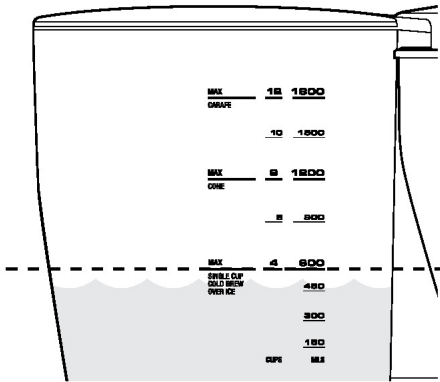

NOTE

DO NOT fill the water tank more than SINGLE CUP line or the volume of the cup used to receive the coffee. It will overflow as the machine brews until the water tank becomes empty.

2. Place your empty cup underneath the brew basket outlet.
3. We recommend using cone filter basket insert for single cups. It ensures proper contact between the brew water and the ground coffee.
4. To change the basket type, rotate the SELECT dial to Settings and press to enter the Settings mode and select "Basket Type".
5. Rotate the dial to select "Cone", and press dial to select. "Cone" will be displayed on the LCD.
6. Insert the Cone filter basket into the brew basket. Use the alignment marks as a guide.
7. Place a cone shaped paper filter into the cone filter basket.
8. Grind the correct amount of whole bean coffee for the amount you are brewing. 1 level Breville scoop of ground coffee is suitable for 150ml of water.
9. Select desired brewing mode, Fast, Gold, MyBrew or Strong.
10. Press START|CANCEL to begin brewing.



Programming

AUTO START

Allows you to automatically start brewing at preset time.

1. Set filter basket type for the amount of coffee you're brewing.
2. Select your brewing mode.
3. Fill the water tank with enough fresh cold water for the amount of coffee you're brewing.
4. Insert the brew basket with your desired insert or paper filter and add coffee.
5. Insert the appropriate cup or the carafe with the lid locked in place into the machine.
6. Press the AUTO START button.

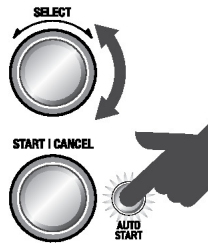
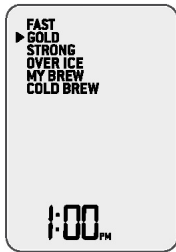

7. The machine will prompt you to set the time for Auto Start. Rotate the SELECT dial to adjust Auto Start time press SELECT to set. Auto Start is now set and the machine will enter Auto Start mode, brewing automatically at the set Auto Start time.



NOTE

If the clock hasn't been set, the machine will prompt you to set the clock. Ensure the clock is correct. The clock will reset every time the unit is unplugged.

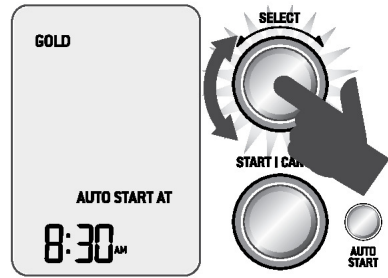

8. Pressing START|CANCEL will cancel Auto Start.

SETTINGS

- SET CLOCK: Set the time displayed on LCD.
- SOUND: Sound volume is adjustable and also can be turned off.
- STANDBY: Adjust time to automatically enter STANDBY mode after a period of no use.
- FILTER TYPE: Factory setting is Flat basket, adjustable when using the Cone filter basket insert.

ENTERING STANDBY MODE AT ANY TIME

Press the START|CANCEL button for 3 seconds.

DEGREE INDICATION PREFERENCE (°C/°F)

To switch between °F and °C, press SELECT dial and AUTO START button together. Rotate the SELECT dial to select, then press SELECT dial to set.

CHILD-LOCK

To prevent children from possible danger, child-lock feature is available. Press and hold AUTO START button for 5 seconds. LCD will display "CL" when it is locked. Repeat this again or unplug the unit to unlock.



Tips

WHOLE BEANS

- **FRESH IS BEST!** Freshly roasted, quality coffee is key to making great tasting coffee. Peak flavour potential is 5-20 days after roast. Always look for a “Roasted On” date on the bag. Avoid coffee with a “Best Before” or “Use By” date as you never know when it was roasted.
- Coffee flavour and strength are a personal preference. Vary the type of coffee beans and the amount of ground coffee to achieve your preferred taste.
- Freshly ground beans are the key to making coffee with more flavour and body. Pre-ground coffee will have lost most of its flavour and aromatics, so always grind right before you brew for superior taste.
- Store coffee beans in a dark, cool and dry place. Vacuum seal if possible.
- Buy coffee beans in small batches to reduce the storage time and store no more than one week's supply at any time.

PRE-GROUND COFFEE

- Pre-ground coffee is convenient, but will never taste as good as coffee ground right before you brew. We recommend investing in a quality burr grinder so you can grind fresh whole bean coffee right before you brew and enjoy superior tasting coffee.
- The grind will affect the rate at which the water flows through the coffee in the coffee basket and therefore the taste of the coffee. If the grind is too fine the water will not flow through the coffee and may clog or overflow the coffee basket. It may pass through the mesh basket filter leaving sediment in the cup or carafe. The resulting coffee will be over extracted, too dark and bitter. If the grind is too coarse the water will flow through the coffee too quickly. This will result in an under-extracted coffee lacking in flavour.
- Always use “drip filter grind” suitable for use with a drip coffee machines. Never use “Espresso grind” as the finer grind size may cause the coffee basket to block and will be over-extracted.

COFFEE/WATER RATIO

We recommend 1 level Breville scoop of coffee grounds per 150ml cup of water. Adjust the amount according to your individual taste. The maximum capacity for pre-ground coffee is 12 level Breville scoops. Exceeding this amount may cause the coffee basket to overflow.

Cups of coffee (150ml cup)	1	2	3	4	5	6	7	8	9	10	11	12
Spoons of coffee grinds	1 (8.25g)	2 (16.5g)	3 (24.75g)	4 (33g)	5 (41.25g)	6 (9.5g)	7 (57.75g)	8 (66g)	9 (74.25g)	10 (82.5g)	11 (90.75g)	12 (99g)
Water amount	150ml	300ml	450ml	600ml	750ml	900ml	1.05L	1.2L	1.35L	1.5L	1.65L	1.8L

BLOOMING

- When coffee is roasted, CO₂ is trapped inside the bean. Coffee grounds release this CO₂ when hot water hits them, and this is called “blooming”. Your Brewer can automatically adjust bloom time by controlling the water flow. Blooming can have an impact on the aromas and flavours of the brewed cup. If the coffee is overly bitter shorten bloom time, and if it’s sour make it a little longer.

PRE-HEATING

- Pre-heat the carafe or cup for best results. A pre-heated carafe or cup will help maintain the coffee’s optimal temperature and keep coffee hotter for longer. Fill with hot water for about 30 seconds then discard the water.

WATER QUALITY

- Fresh, good-tasting water is essential for a perfect cup. If the water contains excessive sediment, or has an ‘off’ taste or odor, we recommend using filtered water.

ICED COFFEE

- Iced coffee is at its best when the coffee is brewed strong because the coffee is diluted by the melting ice cubes. To achieve great Iced coffee we recommend brewing in OVER ICE mode. Fill the tank ensuring the water level does not exceed the 600ml level.
- Fill the brew basket with twice the amount of coffee you’d normally use for regular brewed coffee.
- Brew into the carafe.
- Once the brewing cycle is complete, transfer the coffee to a heatproof pitcher and let cool to room temperature. Refrigerate until cold, at least 2 hours or overnight. Fill glasses with ice cubes. Pour the coffee into the glasses, filling them to within 4cm of the rim. Top each glass with cream, milk, syrups or sweeteners as desired.



NOTE

If using granulated sugar as a sweetener, add while the coffee is hot to encourage the sugar to completely dissolve.

- To avoid a diluted taste, you can also use regular strength coffee and serve it over coffee ice cubes. Prepare coffee ice cubes by pouring cool coffee into ice-cube trays and freezing.

COLD BREW

Your Brewer will produce a maximum of 600ml of Cold Brew. Due to the long duration (typically 4-14 hours) of the brewing process we recommend setting the machine up overnight so the Cold Brew will be ready in the morning.

1. Fill the tank with your desired volume of water ensuring this is below the COLD BREW line.
2. Remove the basket, and ensure both the cone insert and mesh basket filter are removed. Add a large paper filter and then coffee at 2-3 times of regular ratio (approximately 12 scoops for 600ml). Reinsert the basket into the machine.
3. Remove the lid from the carafe and re-insert – the lid must not be on the carafe during the brewing process, alternatively, use another vessel.
4. Navigate to the COLD BREW setting and press START|CANCEL. The machine will then begin brewing the water without the heating element. Once this is complete a countdown timer will display on the LCD indicating when the Cold Brew is finished. At this point the machine will automatically dispense the Cold Brew into the waiting carafe.



NOTE

Brew Time for Cold Brew can easily be adjusted to your preference, anywhere between 5min – 24hrs.



NOTE

Do not add ice to the tank. Cold, chilled water should be added.



NOTE

Ensure the carafe lid is removed for Cold Brew mode.

POUR OVER

Provided pour over adapter is to let your Precision Brewer accommodate your favourite pour over dripper.

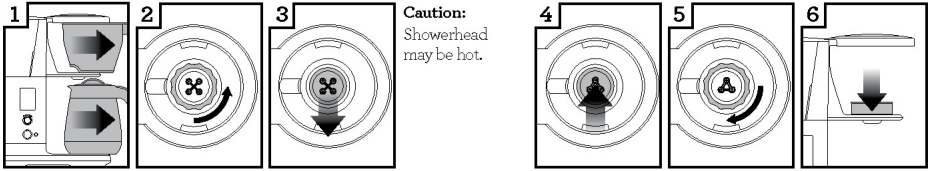

Caution:
Showerhead
may be hot.

1 Remove basket
and carafe

2 Unscrew
showerhead ring

3 Remove
showerhead

4 Fit 'Pour Over'
showerhead

5 Refit showerhead
ring

6 Mount adapter

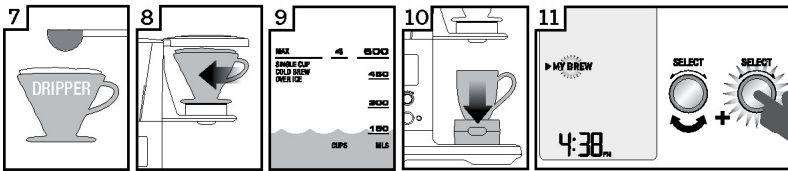

7 Dose with ground
coffee

8 Place dripper on
adapter

9 Fill to cup volume

10 Use case as stand
for cup

11 Rotate SELECT dial to choose
'MY BREW' & press dial

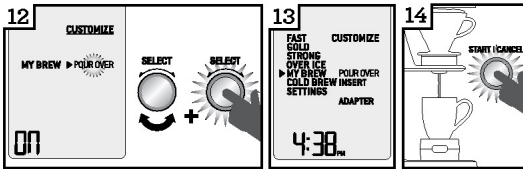

12 Adjust parameters, and select
'POUR OVER' then 'ON'

13 Pour Over mode
is activated

14 Start brewing

Note:
Please ensure that
POUR OVER
mode is on.



Care & Cleaning

Always turn the coffee machine off and remove the plug from the power outlet before cleaning.

CLEANING THE OUTER HOUSING

The outer housing and LCD screen can be cleaned with a soft, damp cloth. Apply cleaner to the cloth and not the LCD surface. Polish with a soft, dry cloth. Cleaning and drying with dry paper towels or abrasive cloths and cleaners may scratch the surface.

CLEANING THE COFFEE BASKET AND MESH BASKET FILTER

Remove the coffee basket. Discard any ground coffee and filter paper. The coffee basket and mesh basket filter can be rinsed under running water. Ensure the fine holes of the mesh basket filter are clear. For a deeper clean, wash the coffee basket and mesh basket filter in warm, soapy water with a soft bristled brush.



CAUTION

The coffee basket, mesh basket or paper filter may still be very hot after brewing. Use caution and allow to cool before removing.

CLEANING THE CARAFE

After each use, empty the carafe. Do not let brewed coffee stand overnight as this can cause the carafe to stain. Rinse the carafe and carafe lid under warm running water. For a deeper clean, we recommend regularly washing the carafe in warm, soapy water using a soft bristled brush. Do not use abrasive cleansers, pads or cloths which can scratch the surface. Rinse and dry thoroughly.

CLEANING THE SHOWERHEAD

Simply wipe down the showerhead area periodically. However, if a more thorough clean is required, the Showerhead can be removed by unlocking the Showerhead Ring. Rotate clockwise then remove the Showerhead for cleaning. Once complete, reinstall the Showerhead.

DESCALING

After regular use, hard water can cause mineral build up in internal components, reducing the brewing flow, brewing temperature, power of the machine, and taste of the coffee. We recommend to descale regularly. When LCD shows “DESCALE” (flashing), descaling cycle is needed.



NOTE

It takes approximately 15 minutes to complete descaling cycle.

1. Empty the tank. Prepare a descale solution in accordance with manufacturer's instructions. Pour this solution into the empty water tank.
2. Place the basket and the carafe into position under the drip stop outlet (Ensure the carafe is empty and the lid is securely locked).
3. Press SELECT button for 3 seconds to start descaling cycle. LCD will show “dSL” for 1 second and then tell remaining time of descaling cycle.
4. When the descaling process is finished, the LCD screen will go back to the main menu. To completely remove residual water in the tank, invert the machine and brew with fresh water twice. Discard the water from the carafe and rinse thoroughly.



NOTE

We recommend to brew through again after descaling to brew out the residue descale solution.



NOTE

You cannot stop the descaling process mid cycle. Force stop by unplugging the cord from the power outlet.

FACTORY RESET

This is to reset the machine to the factory settings, including water hardness setting. Hold the START button, the SELECT button, and AUTO START button altogether for 3 seconds. When LCD shows “rES” (flashing), press SELECT button to start. Then next prompt asks “YES” or “no” to confirm. Rotate and press SELECT dial/button.



Troubleshooting

PROBLEM	POSSIBLE CAUSE	WHAT TO DO
Coffee too strong or weak	<ul style="list-style-type: none">• Amount of coffee and water is not correct (1 spoon : 150ml cup).	<ul style="list-style-type: none">• Check correct amount of coffee or water is used.
Coffee leaking from basket when removed	<ul style="list-style-type: none">• The basket drip-stop seal doesn't cover the gap properly due to foreign material.	<ul style="list-style-type: none">• Check that there is no obstruction in the basket drip-stop seal. Wash out the basket seal by turning the basket upside down, and pressing down and rinsing into the seal to clear any particles obstructing that area.
Coffee overflowing from the basket (CAUTION: If the basket has overflowed remove slowly and with caution)	<ul style="list-style-type: none">• Carafe is not inserted.• Amount of coffee and water is not correct (1 spoon : 150ml cup).• Grind size is too fine.• Too much grinds in the basket.• No paper in the basket.• Putting paper into mesh basket filter.• Pour Over mode selected when using the default brewing basket.	<ul style="list-style-type: none">• If you are brewing with carafe, check that the carafe is inserted.• Check that the correct amount of coffee and water is used for the operation.• Correct grind size/amount.• Use mesh basket filter without paper and other baskets with paper.• Deselect the Pour Over mode in the Mybrew menu.
'FILL TANK' on LCD screen	<ul style="list-style-type: none">• Water tank is empty or not enough water to brew the selected volume.• Sensors may be dirty.	<ul style="list-style-type: none">• Open the lid and pour the desired amount of cold, preferably filtered water.• While the tank is empty wipe the sensor prisms in the tank with a cloth.
Auto Start does not function	<ul style="list-style-type: none">• Auto Start does not repeat after it has been activated.	<ul style="list-style-type: none">• Re-engage the Auto Start mode for each time that it needs to be used.
Shows 'CLOCK' when Auto Start is pressed	<ul style="list-style-type: none">• Current time should be set before setting Auto Start.	<ul style="list-style-type: none">• Set the current time before using Auto Start.
Clock does not remember time	<ul style="list-style-type: none">• Clock is cleared every time the unit is unplugged.	<ul style="list-style-type: none">• Keep the unit plugged.
Auto Start starts at the wrong time	<ul style="list-style-type: none">• Current time is not correct.	<ul style="list-style-type: none">• Check that the current time is correct.
Carafe overfilling	<ul style="list-style-type: none">• Carafe is not completely empty before brewing.• Amount of water is too much.	<ul style="list-style-type: none">• Check that the carafe is empty before brewing.• Check that the MAX line on the water tank is not exceeded.• Ensure water runs freely through carafe lid.

PROBLEM	POSSIBLE CAUSE	WHAT TO DO
LCD shows 'FILL TANK' when there is water in the tank	<ul style="list-style-type: none"> • Check that the unit is not in direct sunlight or direct bright lighting. 	<ul style="list-style-type: none"> • Move unit away from the light source.
Brew doesn't start	<ul style="list-style-type: none"> • There is no water in the water tank. • Each brewing mode has different water amount limits, and it does not brew when the amount is beyond the limit. 	<ul style="list-style-type: none"> • Check that the water tank is filled. • Check the water amount limits for each mode.
Showerhead falls out	<ul style="list-style-type: none"> • The showerhead may loosen and fall out from time to time if not inserted or tightened correctly. 	<ul style="list-style-type: none"> • Please wash the showerhead ring and seal and re-insert.
The mesh filter in the water tank loosens and floats	<ul style="list-style-type: none"> • Mesh filter is not inserted or tightened correctly. 	<ul style="list-style-type: none"> • Call Breville Consumer Support.
Carafe drip stop stays down	<ul style="list-style-type: none"> • The drip stop is stuck. 	<ul style="list-style-type: none"> • Pull the drip stop back up. • Clean the drip stop for any foreign objects of coffee grinds or stains. • If the problem persists and drip stop does not return to top position please call Breville Consumer Support.
Unit produces excessive steam while brewing or runs for extended periods with only steam output	<ul style="list-style-type: none"> • Brewing performance is affected by scale accumulated by hard water. • Brewing temperature profile is not properly set. 	<ul style="list-style-type: none"> • Descale the unit. • Call Breville Consumer Support if problem persists.
'DESCALE' on LCD screen (flashing)	<ul style="list-style-type: none"> • Brewing performance is affected by scale accumulated by hard water. 	<ul style="list-style-type: none"> • Descale the unit.
Unit shows "too hot"	<ul style="list-style-type: none"> • Unit has been run too many times back to back and the components are overheated. 	<ul style="list-style-type: none"> • Let unit rest for at least 20mins before starting another cycle.
Shows Err1, Err2, Err4, or Err5	<ul style="list-style-type: none"> • Internal system error. 	<ul style="list-style-type: none"> • Unplug unit and let cool and retry. Call Breville Consumer Support if problem persists.

PROBLEM	POSSIBLE CAUSE	WHAT TO DO
Shows Err7	<ul style="list-style-type: none"> • There is a blockage in the system. 	<ul style="list-style-type: none"> • Empty the tank, remove any blockage, and wipe. • Cool down and run FAST cycle with 1L. • Descale the unit. • Call Breville Consumer Support if problem persists.
Shows Err3	<ul style="list-style-type: none"> • The issue indicates an unstable power supply. 	<ul style="list-style-type: none"> • Unplug and check plug connections and power supply with caution. Let cool and retry. Call Breville Consumer Support if problem persists.
OVER ICE and COLD BREW modes are disabled	<ul style="list-style-type: none"> • If the water is more than 600ml, these modes are disabled. 	<ul style="list-style-type: none"> • Reduce the amount of water in the tank.
Unit does not use the full amount of water in the water tank	<ul style="list-style-type: none"> • There is a blockage in the system. 	<ul style="list-style-type: none"> • Empty the tank, remove any blockage, and wipe, inspect and clean any obstruction and coffee/fibre/dirt build up from the mesh filter at the bottom of the water tank. • Cool down and run FAST cycle with 1L. • Descale the unit. • Call Breville Consumer Support if problem persists.
Unit brewing slow	<ul style="list-style-type: none"> • There is a blockage in the system. 	<ul style="list-style-type: none"> • Empty the tank, remove any blockage, and wipe, inspect and clean any obstruction and coffee/fibre/dirt build up from the mesh filter at the bottom of the water tank. • Cool down and run FAST cycle with 1L. • Descale the unit. • Call Breville Consumer Support if problem persists.

PROBLEM	POSSIBLE CAUSE	WHAT TO DO
Uneven coffee bed	<ul style="list-style-type: none"> Showerhead may not be attached/secured properly. 	<ul style="list-style-type: none"> Check the attachment of the showerhead locking ring and shower head. Clean showerhead from any blockage or scale buildup.
Pourover adaptor is lifted out of position when brewing	<ul style="list-style-type: none"> pourover mode not selected. 	<ul style="list-style-type: none"> Go to mybrew mode and select 'on' to engage pourover mode.

Breville Customer Service Centre

Australian Customers

Mail: Locked Bag 2000
Botany NSW 1455
AUSTRALIA

Phone: 1300 139 798

Fax: (02) 9700 1342

Web: www.breville.com.au

New Zealand Customers

Mail: Private Bag 94411
Botany Manukau 2163
Auckland NEW ZEALAND

Phone: 0800 273 845

Fax: 0800 288 513

Web: www.breville.co.nz

Breville
Thought for food

Breville is a registered trademark of Breville Pty. Ltd. A.B.N. 98 000 092 928.
Copyright Breville Pty. Ltd. 2017.

Due to continued product improvement, the products illustrated/photographed
in this brochure may vary slightly from the actual product.