

the One° Precision Poacher™

Instruction Book - BEG800



Breville®



Contents

2	Breville Recommends Safety First	
6	Components	
8	Functions	
	- Before First Use	8
	- Setting Clock	8
	- Getting the Best Results	8
	- Probe	8
	- STEAM	9
	- POACH	9
	- BOIL	9
	- SCRAMBLE	10
	- EGGSPERT	10
	- SOUS VIDE	10
	- Delay Start	11
11	Care & Cleaning	

BREVILLE RECOMMENDS SAFETY FIRST

At Breville we are very safety conscious. We design and manufacture consumer products with the safety of you, our valued customer, foremost in mind. In addition we ask that you exercise a degree of care when using any electrical appliance and adhere to the following precautions.

IMPORTANT SAFEGUARDS

READ ALL INSTRUCTIONS BEFORE USE AND SAVE FOR FUTURE REFERENCE

- Remove and safely discard any packaging material and promotional labels before use.
- To eliminate a choking hazard for young children, remove and safely discard the protective cover fitted to the power plug of this appliance.
- Always ensure the appliance is properly assembled before use. Follow the instructions provided in this book.
- Do not touch hot surfaces. Appliance surfaces are hot during and after operation. To prevent burns or personal injury, always use protective hot pads or insulated oven mitts, or use handles or knobs where available.

- Do not place the appliance near the edge of a bench or table during operation. Ensure that the surface is dry, level, clean and free of any liquid and other substances.
- Always operate the appliance on a stable and heat resistant surface. Do not use on a cloth-covered surface, and position the appliance at a minimum distance of 20cm away from walls, curtains, cloths and other heat sensitive materials.
- Do not place this appliance on or near a hot gas or electric burner, or where it could touch a heated oven.
- Do not operate the appliance on a sink drain board.
- Do not use harsh abrasives, caustic cleaners or oven cleaners when cleaning this appliance. Keep the appliance clean and refer to care and cleaning section.

- Do not attempt to operate the appliance by any method other than those described in this booklet.

IMPORTANT SAFEGUARDS FOR ALL ELECTRICAL APPLIANCES

- Unwind the power cord fully before use.
- Do not let the power cord hang over the edge of a bench or table, touch hot surfaces or become knotted.
- Connect only to a 230V or 240V power outlet.
- To protect against electric shock, do not immerse the power cord, power plug or appliance in water or any other liquid.

- Always turn the appliance to the OFF position, switch off at the power outlet, remove the plug and allow all parts to cool before attempting to move the appliance, when the appliance is not in use, before cleaning and when storing.
- Appliance can be used by persons with reduced physical, sensory or mental capabilities or lack of experience and knowledge if they have been given supervision or instruction concerning use of the appliance in a safe way and understand the hazards involved.
- Cleaning and user maintenance shall not be made by children unless they are older than 8 and supervised.
- Keep the appliance and its cord out of reach of children less than 8 years.
- Children shall not play with the appliance.
- It is recommended to regularly inspect the appliance. Do not use the appliance if power cord, power plug or appliance becomes damaged in any way. If damaged or maintenance other than cleaning is required, please contact Breville Customer Service on 1300 139 798.
- Any maintenance, other than cleaning, should be performed at an authorised Breville Service Centre.
- Please take care when handling after use. The heating element surface is subject to residual heat after use.
- When cleaning or using, take care to avoid injuries with the egg cooking device.
- The use of attachments not sold or recommended by Breville may cause fire, electric shock or injury.

- Close supervision is necessary when any appliance is used by or near children.
- Extreme caution must be used when moving an appliance containing hot oil or other liquids.
- This appliance is for household use only. Do not use this appliance for other than its intended use. Do not use in moving vehicles or boats. Do not use outdoors. Misuse may cause injury.
- The appliance is not intended to be operated by means of an external timer or separate remote control system.



Hot Surfaces
Do Not Touch

This symbol indicates, temperature of accessible surfaces may be high when the appliance is operating and for some time after use.

- The installation of a residual current device (safety switch) is recommended to provide additional safety protection when using electrical appliances. It is advisable that a safety switch with a rated residual operating current not exceeding 30mA be installed in the electrical circuit supplying the appliance. See your electrician for professional advice.

CAUTION

Avoid injuries from the egg pricking device. Note the inside of egg topper cutting rim can be sharp. Use with caution.

SAVE THESE INSTRUCTIONS



Components

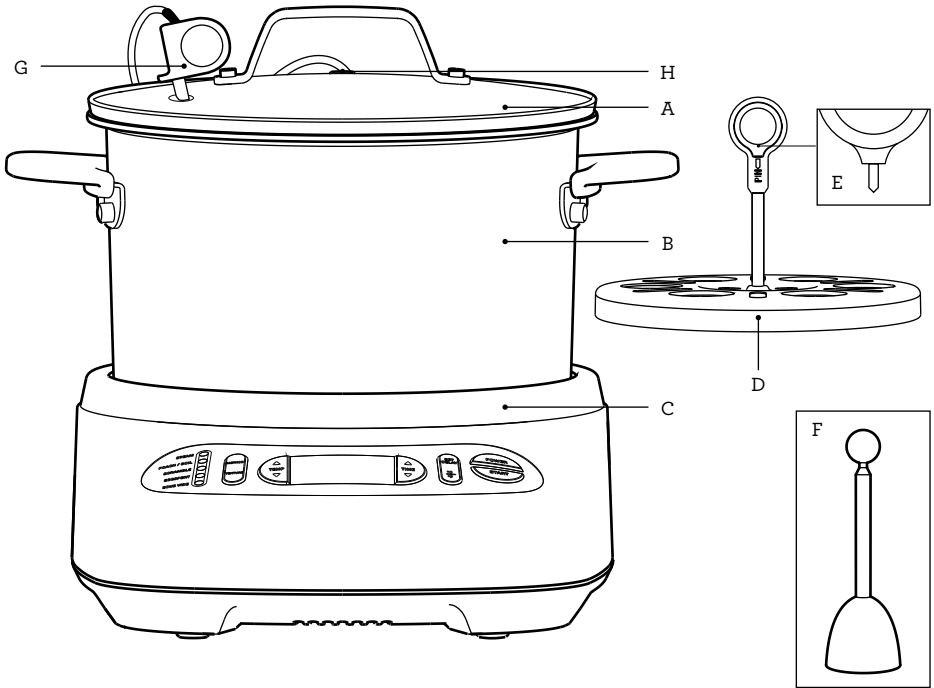

A. Cooking Vessel Lid

B. 2.5L Aluminium Pot

C. Heating Base

D. Egg Tray

Holds up to 6 eggs at once.

E. Egg Piercer

Use to pierce eggs before cooking.

Pierce base of egg gently.

F. Egg Topper

Useful tool when you want to open
EGGSPERT, SOUS VIDE and steamed
eggs.

G. Probe

H. Probe Holster at rear of unit (not shown)

Power cord with Breville Assist® Plug
(not shown)

CONTROL PANEL

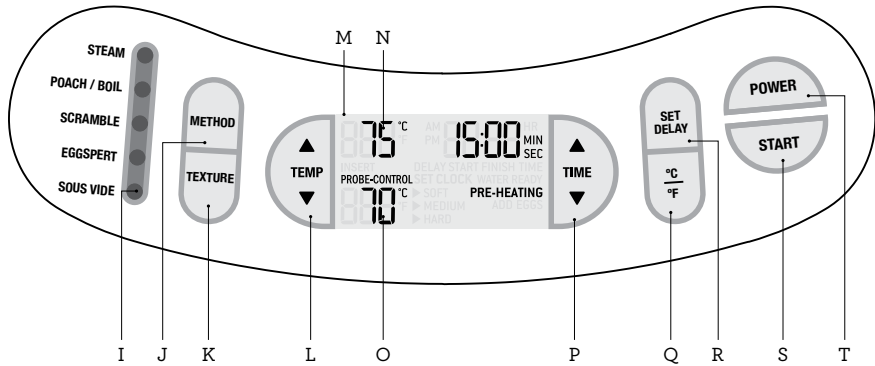

- I. Method indicator lights**
Indicates which method is currently selected.
- J. METHOD button**
Select between STEAM, POACH/BOIL, SCRAMBLE, EGGSPERT and SOUS VIDE.
- K. TEXTURE button**
Choose from soft, medium or hard texture to suit your liking.
- L. TEMP button**
Precisely adjust temperature.
- M. LCD screen**
Easy to read intuitive screen.
- N. Set temperature**
The target temperature to cook foods.
- O. Probe Temperature**
The actual temperature that probe is reading.
- P. TIME button**
To adjust the clock and the cooking time.
- Q. °C/°F button**
Switch between Celsius and Fahrenheit.
- R. SET DELAY button**
Set finish time to have eggs cooked perfectly when you are ready.
- S. START button**
- T. POWER button**
Used to power on/off unit.



Functions

BEFORE FIRST USE

Carefully unpack your Precision Poacher™ and keep all packing material until all the parts have been found and the appliance has been assembled. Remove all promotional stickers.

To remove any dust that may have accumulated during packing, wash the cooking vessel, lid, egg tray, egg piercer and egg topper in warm soapy water. Rinse in clean water and dry thoroughly. Wipe exterior of base and the probe with a soft damp cloth and then dry thoroughly.

Carefully read all instructions before operating and save for future reference.

SETTING CLOCK

1. Once you plug the product in, the unit will enter the standby mode.
2. Press time arrows up and down to set your time. Press and hold for faster time change.
3. Confirm the clock setting by pressing the START button. Alternatively the clock will automatically confirm the time if no button is pressed for 3 seconds.

To change the time

1. Power it down by pressing the power button. Enter the standby mode.
2. Press time arrows up and down to set your time.



NOTE

Once unplugged for 5 seconds, all settings will be reset to factory defaults. Only clock time will be remembered for up to 5 days.

GETTING THE BEST RESULTS

Default cooking times are a guide only. Please consider below and adjust your cooking time and temperature according to your liking.

- Fresh eggs yield the best results, especially in POACH, EGGSPERT and SOUS VIDE.
- Fresh egg are considered as less than a week old. These eggs normally have about 5 weeks before the best before date and have been kept refrigerated.
- The default setting is based on 60g eggs. Larger eggs will cook more slowly, so when using large eggs, increase the cooking time. To adjust cooking time, press UP/DOWN TIME arrows. If cooking time is adjusted, the relevant TEXTURE indicator arrow will disappear for BOIL and STEAM method.
- Refrigerated or eggs at room temperature (approximately 21°C) can be used for preset settings.

PROBE

- The use of the Probe is required for POACH/BOIL, SOUS VIDE & EGGSPERT method.
- The tip of the probe should be immersed in water and NOT touching food.
- The probe is NOT to be inserted directly into food.
- If you start POACH/BOIL, EGGSPERT or SOUS VIDE cycles without inserting the probe the screen will display an error message (ERR). Insert probe and press START to resume the cooking cycle.



IMPORTANT

The temperature probe is a precision instrument and should be handled with care. Avoid over-stretching or kinking the cable.

STEAM

A fast and easy way of cooking soft, medium or hard textured eggs in less time than traditional boiled eggs.

1. Press METHOD button to select STEAM function.
2. Press the TEXTURE button to select your egg doneness from SOFT, MEDIUM and HARD. The arrow indicator will shift down one position per press and the default time will adjust to suit the setting.
3. Place eggs into egg tray and lower into cooking vessel.
4. Fill the cooking vessel with cold tap water to water fill line, cover with the lid and place vessel on the heater base.
5. Press START to begin preheating. PREHEATING icon will appear and screen will change to orange.
6. Once the unit has reached the correct temperature, the unit will sound one beep, the PRE-HEATING icon will disappear and the TIMER will begin counting down.
7. Once the cooking cycle has finished, the screen will display END and will sound three beeps and backlight returns to blue colour.
8. Remove eggs from water and run immediately under cold tap water to stop the eggs from over cooking or serve immediately.



NOTE

Always fill the water to the STEAM fill line for consecutive steaming.

POACH

Make perfectly cooked poached eggs using precise cooking temperatures.

1. Press METHOD button to select POACH/BOIL setting. The default temperature and time is shown on the LCD screen.
2. Remove egg tray and fill cooking vessel with water to fill line.
3. Put the vessel on the heating base, cover with lid, insert probe into the steam vent in the lid and press START button.
4. Once water temperature has been reached, the unit will sound one beep.
5. Carefully crack up to four eggs into cooking vessel and press the START button. Make sure the lid is back on and the probe is back into the water, not touching the eggs.
6. Once timer has ended, remove poached eggs with a silicone slotted spoon.



NOTE

After the cooking cycle, the cooker will automatically hold the water temperature for your next round of poaching. If you do not wish to conduct another round, press the POWER button to turn the unit off.

BOIL

For perfectly cooked boiled eggs each and every time.

1. Press METHOD button to select POACH/BOIL function.
2. Increase the temperature to 100°C. This means you are entering into the BOIL method and the texture menu (Soft, Medium and Hard) will appear.
3. Press the TEXTURE button to select your egg doneness from SOFT, MEDIUM and HARD. The arrow indicator will shift down one position per press and the default time will adjust to suit the setting.
4. Remove egg tray and fill cooking vessel with water to fill line.

- Put the vessel on the heating base, cover with lid, insert probe into the steam vent in the lid and press START button.
- Once water temperature has been reached, the unit will sound one beep.
- Place eggs into egg tray and lower into cooking vessel, cover with lid and press START button. Make sure the probe is back into the water, not touching the eggs.
- Once the cooking cycle has finished, remove eggs from water and run immediately under cold tap water to stop the eggs from over cooking or serve immediately.



NOTE

After the cooking cycle, the cooker will automatically hold the water temperature for your next round of boiling. If you do not wish to conduct another round, press the POWER button to turn the unit off.

SCRAMBLE

Creates soft and creamy textured scrambled eggs, ready to be spooned onto your favourite toast.

- Press METHOD button to select SCRAMBLE setting.
- Remove egg tray and set aside. Whisk two to six eggs together in a mixing bowl and season to taste with salt and pepper.
- Press START button and add 1 tablespoon of butter or a little olive oil to cooking vessel.
- Pour in eggs and stir gently with a silicone spatula, bringing the outside eggs into the centre and vice versa.
- Press POWER button to stop the cycle.
- Remove from the heat – the residual heat of the pan will continue to cook the eggs.



NOTE

For best results, stir gently until eggs still look silky, a little runny and slightly underdone.

EGGSPERT

A quick and simple way to get soft and creamy textured eggs in the shell.

- Press METHOD button to select EGGSPERT function. The default temperature and time is shown.
- Put your eggs into the egg tray, lower egg tray into the vessel.
- Fill the cooking vessel with water to the fill line.
- Cover with lid, insert probe into the steam vent in the lid and press START button. Make sure the tip of the probe is not directly touching the eggs.
- Once the water has reached the correct temperature, the unit will sound one beep, the PRE-HEATING icon will disappear and the TIMER will begin counting down.
- Once timer has ended, lift the egg tray up to take eggs out of the vessel.
- Use the egg topper to crack open the tops of the eggs and pour eggs out to serve.

SOUS VIDE

Sous vide method means the foods are slowly cooked at a precise temperature. When eggs are cooked at a low temperature in their shells, you can expect a soft and creamy texture.

Precision Poacher's precise temperature control of 1° increments and cooking times of up to 12 hours provides the ability to cook different ingredients in SOUS VIDE method. Explore the SOUS VIDE setting to try different kinds of food to get tender and juicy results.

- Press METHOD button to select SOUS VIDE setting. The default temperature and time is shown.
- Fill the cooking vessel with water to the fill line.
- Put the egg tray into the cooking vessel as this will prevent your food to directly touching the bottom of the vessel.
- Cover with lid, insert probe into the steam vent in the lid and press START button.

- Once water temperature has been reached, the unit will sound one beep.
- Add food, cover with lid, insert probe into the steam vent in the lid and press START button. The timer will begin to count down.



NOTE

For eggs, place them in the egg tray in their shell and lower them into the vessel. For other foods, vacuum seal in a sous vide safe plastic bag and drop the bag into the water. Make sure the food is fully submerged.

- Once the timer has ended, lift the egg tray up and remove your food from the vessel.

DELAY START

SET DELAY can be used for selected functions. For STEAM and EGGSPERT this allows you to program the time in which your eggs will be finished cooking and ready to eat.

For POACH/BOIL and SOUS VIDE, this allows you to program the time in which your water will be at temperature and ready to use.

Set your cooking program as desired by following instructions for each method, then program the delay start function by:

- Press the SET DELAY button and the finish time will appear. The default finish time which will be displayed is 7:00AM.
- To adjust your preferred finish time, use the UP/DOWN TIME arrows.
- Press and hold UP/DOWN TIME arrow to rapidly adjust time.
- Confirm the finish time by pressing the SET DELAY button.
- The screen will show the programmed FINISH TIME and the PRESS START icon will show. Press the START button to begin the cooking program. The back light of the screen will turn-off and the unit will enter the power saving mode.

- Do not unplug or change setting while in DELAY START mode, as all settings will be lost.
- If SET DELAY is chosen and the clock has not been set, the unit will flash SET CLOCK icon. You will not be able to continue without setting the clock. Refer to SETTING CLOCK instructions (pg 8).
- If the program doesn't have enough time to complete the DELAY START program, it will notify you with three beeps.



Care & Cleaning

- Always turn the power off and remove the plug from the power outlet before cleaning the egg cooker.
- The vessel, lid & egg tray can be washed in hot soapy water. The lid & egg tray are dishwasher safe.
- Do not use chemicals, steel wool or harsh abrasives to clean the non-stick surface of the cooking vessel.
- The heating base and the probe can be wiped over with a damp cloth.
- Always use wood or silicone cooking utensils when using the product.

the One° Precision Poacher can cook various foods. For more recipes please see included recipe cards or visit www.Breville.com.au

Breville Customer Service Centre

Australian Customers

Mail: Locked Bag 2000
Botany NSW 1455
AUSTRALIA

Phone: 1300 139 798

Fax: (02) 9700 1342

Email: Customer Service:
askus@breville.com.au

Web: www.breville.com.au

New Zealand Customers

Mail: Private Bag 94411
Botany Manukau 2163
Auckland NEW ZEALAND

Phone: 0800 273 845

Fax: 0800 288 513

Email: Customer Service:
askus@breville.co.nz

Web: www.breville.co.nz

Breville®
Thought for food

Breville is a registered trademark of Breville Pty. Ltd. A.B.N. 98 000 092 928.
Copyright Breville Pty. Ltd. 2016.

Due to continued product improvement, the products illustrated/photographed
in this brochure may vary slightly from the actual product.