

Breville

Breville Customer Service Centre

Australian Customers

Mail: PO Box 22
Botany NSW 2019
AUSTRALIA

Phone: 1300 139 798

Fax: (02) 9384 9601

Email: Customer Service:
askus@breville.com.au

New Zealand Customers

Mail: Private Bag 94411
Botany Manukau 2163
Auckland NEW ZEALAND

Phone: 0800 273 845

Fax: 0800 288 513

Email: Customer Service:
askus@breville.com.au

www.breville.com.au

Breville is a registered trademark of Breville Pty. Ltd. A.B.N. 98 000 092 928.
Copyright Breville Pty. Ltd. 2012.

Due to continued product improvement, the products illustrated/photographed
in this brochure may vary slightly from the actual product.

Suits all BMO300 models Issue - B12

Breville

the Quick & Easy™

Instruction Booklet



Suits all BMO300 models

CONGRATULATIONS

on the purchase of your new
Breville product

CONTENTS

- 4** Breville recommends safety first
- 10** Know your Breville product
- 13** Operating your Breville product
- 23** Hints & tips
- 25** Care & cleaning
- 27** Troubleshooting
- 29** Recipes

At Breville we are very safety conscious. We design and manufacture consumer products with the safety of you, our valued customer, foremost in mind. In addition we ask that you exercise a degree of care when using any electrical appliance and adhere to the following precautions.

IMPORTANT SAFEGUARDS

READ ALL INSTRUCTIONS BEFORE USE AND SAVE FOR FUTURE REFERENCE

- Remove and safely discard any packaging material and promotional labels before using the Breville Microwave for the first time.
- To eliminate a choking hazard for young children, remove and safely discard the protective cover that is fitted to the power plug of the Breville Microwave.
- Do not place the microwave oven near the edge of a bench or table during operation. Ensure all surfaces are level, clean and free of water or any other substances.
- Do not place the microwave oven on or near a hot gas or electric burner, or where it could touch a heated oven.
- When using the microwave oven, provide adequate air space above and on all sides for air circulation. (see page 14 Installation, point 2).
- Always operate the microwave oven on a heat-resistant surface. Do not use on a cloth-covered surface, near curtains or other flammable materials.
- Do not use the microwave oven on a metal surface, for example a sink drain board.
- Always ensure the microwave oven is properly assembled before connecting to the power outlet and operating. Do not use the oven without the roller ring and glass turntable tray in place. Ensure the turntable tray is positioned correctly into the indents on the rotating shaft.
- The microwave oven is not intended to be operated by means of an external timer or separate remote control system.
- Never use the microwave oven without food or water in the oven cavity. Operating the microwave oven when empty could cause damage to the appliance.
- Do not leave the microwave oven unattended when in use.
- Do not touch hot surfaces. Allow the microwave oven to cool before moving or cleaning any parts.
- Do not place or store anything on top of the microwave oven.
- Always ensure the microwave oven is turned off at the power outlet and the cord is unplugged from the power outlet before attempting to move the appliance, when not in use, if left unattended and before disassembling, cleaning or storing.
- Keep the appliance clean. Follow the cleaning instructions provided in this book (page 25).
- Always turn the microwave oven off by pressing the STOP/CLEAR button, switch off at the power outlet and unplug at the power outlet when it is not in use.
- Before cleaning, always press STOP/CLEAR position, switch off at the power outlet, unplug at the power outlet and remove the power cord.

IMPORTANT SAFEGUARDS FOR ALL ELECTRICAL APPLIANCES

- Fully unwind the power cord before use.
- Do not let the power cord hang over the edge of a bench or table, touch hot surfaces or become knotted.
- To protect against electric shock do not immerse the power cord, power plug or appliance in water or any other liquid.
- The appliance is not intended for use by persons (including children) with reduced physical, sensory or mental capabilities, or lack of experience and knowledge, unless they have been given supervision or instruction concerning use of the appliance by a person responsible for their safety.
- Children should be supervised to ensure that they do not play with the appliance.
- It is recommended to regularly inspect the appliance. To avoid a hazard do not use the appliance if power cord, power plug or appliance becomes damaged in any way. Return the entire appliance to the nearest authorised Breville Service Centre for examination and/or repair.
- Any maintenance other than cleaning should be performed at an authorised Breville Service Centre.
- This appliance is for household use only. Do not use this appliance for anything other than its intended use. Do not use in moving vehicles or boats. Do not use outdoors. Misuse may cause injury.
- The installation of a residual current device (safety switch is recommended to provide additional safety protection when using electrical appliances. It is advisable that a safety switch with a rated residual operating current not exceeding 30mA be installed in the electrical circuit supplying the appliance. See your electrician for professional advice.
- Always turn the appliance to the OFF position, switch off at the power outlet and unplug at the power outlet when the appliance is not in use.
- Before cleaning, always turn the appliance to the OFF position, switch off at the power outlet, unplug at the power outlet and remove the power cord, if detachable, from the appliance and allow all parts to cool.
- Do not place this appliance on or near a heat source, such as hot plate, oven or heaters.
- Position the appliance at a minimum distance of 20cm away from walls, curtains and other heat or stream sensitive materials and provide adequate space above and on all sides for air circulation.

SPECIAL SAFETY INSTRUCTIONS FOR YOUR MICROWAVE OVEN

- Wipe the oven cavity with a soft, damp cloth after each use. Leaving food residue, grease or fat in the cavity could cause the microwave oven cavity to overheat and may cause the microwave oven to smoke or catch fire.
- The microwave oven should be cleaned regularly and any food splattering inside the cavity should be removed. Failure to maintain the microwave oven in a clean condition could lead to deterioration of the surface, adversely affecting the life of the microwave oven and possibly resulting in a hazardous situation.
- If the door seals or any of the microwave oven is damaged, the microwave oven must not be operated until it has been inspected and/or repaired at an authorised Breville Service Centre.

BREVILLE RECOMMENDS SAFETY FIRST

- The microwave oven is intended for heating food and beverages. Drying of food or clothing and heating or warming pads, slippers, sponges, damp cloth and similar may lead to risk of injury, ignition or fire.
- Ensure all food containers and/or plates are suitable for use in the microwave oven. This should be done prior to preparing food for heating or cooking in the microwave oven. Monitor foods and liquids heating or cooking in the microwave oven at all times due to the possibility of containers igniting.
- Containers or plates suitable for use in the microwave oven should not exceed the width of the glass turntable as this may impede the rotation of the turntable and result in food being unevenly cooked.
- Liquids or other foods must not be heated in sealed containers since they are liable to explode.
- Some containers and/or plates may appear suitable for use in the microwave oven but may be coated in a glaze that will absorb the microwave energy, overheat and cause the container to crack. The glaze may also prevent the food from heating/cooking.
- Food and/or liquids should not be heated or cooked directly on the turntable. Food and/or liquids must be placed into a suitable microwave-proof container before placing onto the glass turntable.
- Food and/or liquids should not be heated or cooked in plastic or paper containers or bags, unless specified as suitable for use by the manufacturer, due to the possibility of containers exploding or igniting.
- Metal clips or twist ties should be removed from the packaging as these could cause sparking and/or fire.
- Do not use recycled paper or kitchen paper towelling when cooking. Recycled paper may contain small metal or other impurities which could cause sparking and/or fire.
- Do not use metal containers or utensils in the microwave oven as these could cause sparking and/or fire.
- Only use utensils that are suitable for use in microwave ovens.
- Food grade foil should not be used in the microwave oven as this could cause sparking and/or fire.
- Ensure that lids and caps covering containers are removed prior to placing liquids and/or foods into the microwave oven.
- Feeding bottles and baby food jars should have lids and caps removed before warming or heating in the microwave oven. To avoid burns or scalding after heating, the contents should be stirred or shaken and the temperature checked before serving.
- Always ensure the temperature of food or drink which has been heated or cooked in the microwave oven has been tested before eating, drinking or serving to others, especially children, disabled or elderly people.
- The heating of liquids and beverages in the microwave oven can result in delayed eruptive boiling. Care must be taken when handling any containers containing hot liquids or beverages.
- Do not heat popcorn in the microwave oven unless it has been commercially packaged for microwave use. There may be a number of un-popped kernels that may overcook and burn when popping popcorn. Do not use oil unless recommended by the manufacturer. Do not pop popcorn longer than the manufacturer's instructions (popping time should not exceed 3 minutes). Longer cooking could cause scorching or fire.
- Do not cook any food surrounded by a membrane (such as potatoes, chicken liver, egg yolks, oysters, etc) without first piercing the membrane several times with a fork or similar utensils.

- Fresh eggs in the shell and whole hard-boiled eggs should not be cooked or heated in the microwave oven as they may explode during cooking, at the end of cooking or after removing from the microwave oven.
- Do not heat oil or fat for shallow or deep frying in the microwave oven. Doing so may cause the microwave oven and/or the oil to overheat and/or ignite.
- If any smoke is observed, switch off and unplug the microwave oven at the power outlet. Keep the door closed to stifle any flames.
- Do not attempt to operate the microwave oven by any method other than those described in this instruction book.
- Do not disconnect the microwave oven from the power supply by pulling on the cord to unplug from the power outlet.
- When storing the microwave oven loosely wind the cord. Do not wrap the cord around the microwave oven.
- Only use the temperature probe recommended or supplied together with this microwave oven. This is only applicable if the appliance has the facility to use a temperature sensing probe.

 **WARNING**

Do not attempt to operate the oven with the door open since open-door operation can result in harmful exposure to microwave energy. It is important not to defeat or tamper with the safety interlocks.

 **WARNING**

Do not place any object between the oven front face and the door or allow soil or cleaner residue to accumulate on sealing surfaces.

 **WARNING**

Liquids and other foods must not be heated in sealed containers since they are liable to explode.

**SAVE THESE
INSTRUCTIONS**

⚠ WARNING

If the door or door seals are damaged, the oven must not be operated until it has been repaired by a Breville Service Centre. It is particularly important that the oven door closes properly and that there is no damage to the: (1) Door (bent), (2) Hinges and latches (broken or loosened), (3) Door seals and sealing surfaces.

⚠ WARNING

Do not put any foreign material between the door and door jam of the microwave oven as this could cause excessive leakage of microwave energy.

⚠ WARNING

It is hazardous for anyone other than a Breville Service Centre to carry out any service or repair operation that involves the removal of a cover which gives protection against exposure to microwave energy.

⚠ WARNING

Only allow children to use the oven without supervision when adequate instructions have been given so that the child is able to use the oven in a safe way and understands the hazards of improper use.

⚠ WARNING

When the appliance is operated in the combination mode, children should only use the oven under adult supervision due to the temperature generated.

⚠ CAUTION

Surfaces may be hot during and after use.

⚠ CAUTION

If the apparatus is not maintained in a good state of cleanliness, its surface could be degraded and affect the life span of the product and lead to a dangerous situation.

SPECIFICATIONS	
POWER CONSUMPTION	220-240V, 50Hz, 1500W
TURNTABLE DIAMETER	315mm
OUTPUT	1100W
OUTSIDE DIMENSIONS	314mm (H) 519mm (W) 423mm (D)
OVEN CAPACITY	34 Litres
NET WEIGHT	Approx. 15.3kg

These specifications may change without notice.

SAVE THESE INSTRUCTIONS

KNOW

your Breville product

KNOW YOUR BREVILLE PRODUCT



- A. LED Display**
Shows time, cooking progress and preset functions.
- B. Control panel**
Numeric keypad and cooking functions.
- C. Door release (pull handle)**
- D. Viewing Window**
- E. Turntable assembly & installation**
 - a. Hub (under glass)
 - b. Glass turntable
 - c. Turntable shaft
 - d. Turntable ring assembly

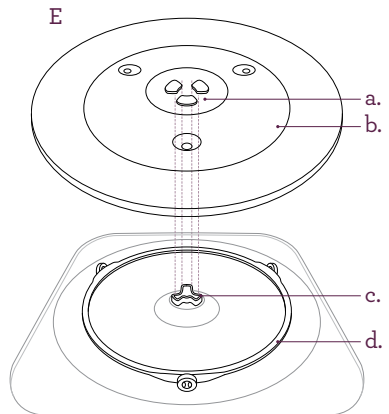

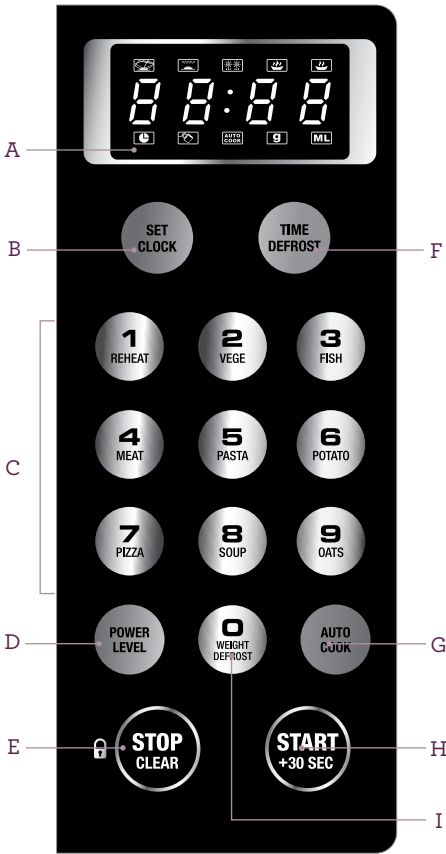

- A. **LED display screen**
Shows selected cooking time, power, symbols and time of the day.
- B. **SET CLOCK**
Press to set the time of the day or recall the time of the day display. The time of the day will be displayed at all times except when the oven is operating.
- C. **NUMBER PAD/AUTO MENUS (1-9)**
Press to input the desired microwave operating time. The number pad can also be used to select the desired auto cook menus.
- D. **POWER LEVEL**
Use to set the microwave oven power levels.
- E. **STOP/CLEAR**
Press to cancel the selected power level, cook or defrost times that are previously programmed. The time of the day clock cannot be cancelled by pressing the CANCEL button. Child lock can also be initiated by holding down the STOP/CLEAR button for 3 seconds.
- F. **TIME DEFROST**
Press to set defrosting time. The oven automatically divides the defrosting time into periods of alternating defrosting and standing times by cycling on and off.
- G. **AUTO COOK**
Press to initiate Auto menu functions (number pad 1-9).
- H. **START/+30 SEC INSTANT START**
Press to start the cooking or defrosting functions. The cooking symbol will appear on the display and the interior of oven light will turn on, the interior fan will operate and the turntable will rotate. Each additional press of the button will add 30 seconds to the cooking time.
- I. **WEIGHT DEFROST**
Use to defrost frozen meat, poultry and seafood by weight. The defrosting time and power level are automatically set once the weight is chosen.

OPERATING

your Breville product

BEFORE FIRST USE

Remove and safely discard any packaging material and labels before using the microwave oven for the first time. Carefully unpack the microwave oven and keep all the packing material until all the parts of the microwave oven have been found and the appliance has been assembled.

To remove any dust that may have accumulated during packing, wash the roller ring and glass turntable tray in warm soapy water, rinse in clean water then dry thoroughly. Wipe the interior and exterior of the microwave oven with a soft, damp cloth then dry thoroughly.

ASSEMBLING THE GLASS TURNTABLE AND TURNING ON THE MICROWAVE OVEN

1. Place the roller ring into position in the indented space in the oven cavity base.
2. Insert the glass turntable into position, matching the indents (hub) on the base of the glass turntable with the indents in the shaft located in the centre of the oven cavity base.

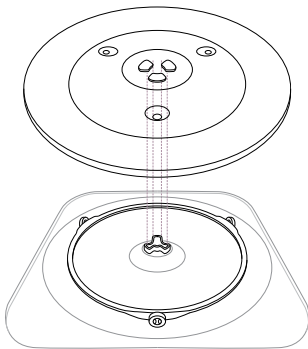

3. Plug the power cord into a 230V or 240V power outlet. Switch on at the power outlet. The microwave oven is now on.

INSTALLATION

1. Select a level surface that provide enough open space for the intake and/or outlet vents.
2. A minimum clearance of 3.0 inches (7.5cm) is required between the oven and any adjacent walls. One side must be open.
 - Leave a minimum clearance of 12 inches (30cm) above the oven.
 - Do not remove the legs from the bottom of the oven.
3. Blocking the intake and/or outlet openings can damage the oven.
4. Place the oven as far away from radios and TV as possible.
5. Operation of microwave oven may cause interference to your radio or TV reception.
6. Plug your oven into a standard household outlet. Be sure the voltage and the frequency is the same as the voltage and the frequency on the rating label.

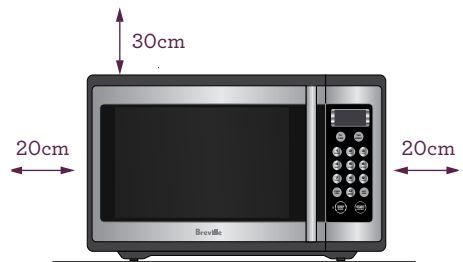

⚠ WARNING

Do not install oven over a range cooktop or other heat-producing appliance. If installed near or over a heat source, the oven could be damaged and the warranty would be void.

⚠ WARNING

Check the oven for any damage, such as misaligned or bent door, damaged door seals and sealing surface, broken or loose door hinges and latches and dents inside the cavity or on the door. If there is any damage, do not operate the oven and contact a Breville Service Centre.

⚠ WARNING

Do not immerse the microwave oven, power cord or plug in water or any other liquid.

INTRODUCTION ON MICROWAVE COOKING

- Microwaves are invisible waves of electromagnetic energy similar to radio waves. Instead of being converted to sound as in a radio or mobile phones, it is converted into a heat source which heats food from the inside.
- Microwaves cook because food molecules of water, fat and sugar react to the energy provided by the microwaves. That energy is absorbed by the food causing the molecules to vibrate quickly. This movement creates friction which causes the food to heat up and therefore cook.
- The energy in a microwave is not distributed evenly throughout the cavity. The turntable rotates constantly while cooking which enables even cooking.
- Microwave cooking is considered the “cool” cooking method as only the food gets hot and surrounding air stays cool.
- Microwaves are safe and can be economical.
- Microwaves need no preheating therefore the kitchen stays cooler. Cooking is cleaner with less odours and washing up is reduced.
- Microwave ovens cook foods rapidly, Some foods are better cooked in a microwave oven as they retain more flavour, texture and goodness, such plain fish fillets, soft fruit, vegetables and fat free cakes.

OPERATING YOUR BREVILLE PRODUCT

- In a microwave the heat is produced INSIDE the food. In all other conventional cooking methods, heat is applied from OUTSIDE through transference of heat by convection or radiation.
- Microwave energy penetrates the food to a depth of about 25mm. Small foods under 5cm in diameter such as eggs are penetrated to the centre from all sides. In larger foods, energy creates heat in the outer layer; this then moves to the centre by conduction, as it does with conventional cooking.

SETTING THE CLOCK

When power is activated, the LED will display 0:00. The input time should be within 0:00–23:59.

Example: To set 12:12.

1. Press the SET CLOCK button, the hour figures will flash, and the indicator for clock will light.
2. Press the number buttons of 1, 2, 1, 2 in order.
3. Press SET CLOCK to finish clock setting. The indicator for clock will go out, ‘.’ will flash, and the time will illuminate.

NOTE

In the process of clock setting, if STOP/CLEAR is pressed or if there is no operation within 1 minute, the oven will go back to the previous status automatically.

MICROWAVE COOKING

1. Using the number pad, input the cooking time; maximum cooking time is 99 minutes and 99 seconds.
2. Press “START / +30 SEC” button to commence operation.

NOTE

Number “0” cannot be input first so when the “0” is pressed before any other numbers, “WEIGHT DEFROST” function will be initiated.

NOTE

This mode will have microwave oven working at 100% power level.

MICROWAVE COOKING WITH POWER LEVELS

Select different microwave power levels and set cooking time as desired.

Option 1

1. Using the number pad, input the cooking time; maximum cooking time is 99 minutes and 99 seconds.
2. Press the POWER LEVEL (continue to press) until desired power level is selected.
3. Press “START / +30 SEC” button to commence operation.

Example: Microwave oven cooking with 50% power for 15 minutes:

- i. Press 1, 5, 0, 0 respectively.

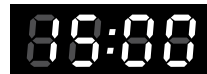

- ii. Press the POWER LEVEL button once: 100%
- iii. Press the POWER LEVEL button twice: 80%
- iv. Press the POWER LEVEL button three times: 50%
- v. Press “START / +30 SEC” button to commence operation.

OPERATING YOUR BREVILLE PRODUCT

Option 2

1. Press the POWER LEVEL (continue to press) until desired power level is selected.
2. Using the number pad, input the desired cooking time.
3. Press “START / +30 SEC” button to commence operation.

Example: Microwave oven cooking with 50% power for 15 minutes:

- i. Press the POWER LEVEL button once: 100%
- ii. Press the POWER LEVEL button twice: 80%
- iii. Press the POWER LEVEL button three times: 50%
- iv. Press 1, 5, 0, 0 respectively.



- v. Press “START / +30 SEC” button to commence operation.

MICROWAVE POWER LEVELS

To set power levels press the POWER LEVEL button and continue to press the POWER LEVEL button until desired power level is selected.

POWER LEVEL BUTTON	MICROWAVE POWER	DISPLAY
1 time	100%	P100
2 times	80%	P80
3 times	50%	P50
4 times	30%	P30
5 times	10%	P10

INSTANT START

When the unit is in waiting state, press START/+30 SEC instantly to start cooking at 30 seconds with 100% microwave power. Each additional press will increase the cooking time by 30 seconds until the accrued time reaches 1 minute 30 seconds or less. By then, each press will increase cooking time by 1 minute, the maximum cooking time is 12 minutes.

Example: Set 3 minutes instant start:

Press START/+30 SEC once to start cooking, LED will display 0:30.

Press START/+30 SEC again for 5 times, and the cooking time will be 3 minutes.

TIPS ON DEFROSTING

- Before defrosting meat, remove the freezer bag or wrap to prevent meat sitting in 'drip', which will otherwise boil as the meat defrosts causing meat to go grey and begin to stew. To remove frozen meat from freezer wrappings, defrost for a few minutes so the wrap is easy to remove.
- Remove meat from Styrofoam tray, as they are not microwave safe.
- Place meat onto a rack with a drip tray to catch juices. Alternatively, place onto a microwave safe plate that is lined with absorbent paper and elevate on an upturned bowl or cup.
- Refer to your user manual for its preferred setting and timing.
- Check the meat throughout the defrosting time. As outer portions of meat thaw, remove them from the microwave. If the edges of meat feel warm, stop microwaving and allow meat to stand for a few minutes or until edges are cold again.
- After defrosting the meat it must be cooked right away. Don't leave it to stand for any length of time at room temperature or in the fridge.
- The energy required for defrosting is much less than for cooking, the microwave causes the ice formed in the food to melt rather than heat.

WEIGHT DEFROST

Example: Defrost beef of 500g:

1. Press WEIGHT DEFROST, LED will display dEF1.
2. Press 5, 0, 0 in order, 'g' will light, the range of defrosting weight is 100g-2000g.
3. Press START/+30 SEC to start defrosting, 'g' will go out, time will be displayed and countdown will start.

TIME DEFROST

Example: To defrost piece of beef in 10 minutes:

1. Press TIME DEFROST, LED will display dEF2.
2. Press 1, 0, 0, 0 to set defrost time.
3. Press START / +30 SEC to start defrosting. Time will be displayed and countdown will start.

AUTO COOK

To enable pre-programmed automatic functions, press the "AUTO COOK" button first and then select the corresponding number pad for the desired auto cook function.

To confirm the desired auto cook function, corresponding number pad will need to be pressed twice.

Example: To select Auto Cook Meat function, input the following steps:

1. Press "AUTO COOK" button
2. Press corresponding number pad "4" to display "A4"
3. Press number "4" again to confirm the selection and default weight "150" will be displayed.
4. Press number "4" until desired weight of the food item is selected (150, 300, 450 and 600 g)
5. Press START / +30 SEC button to commence operation.

OPERATING YOUR BREVILLE PRODUCT

NUMBER PAD	DISPLAY	AUTO FUNCTION
1 REHEAT	A1	REHEAT
2 VEGE	A2	VEGETABLES
3 FISH	A3	FISH
4 MEAT	A4	MEAT
5 PASTA	A5	PASTA
6 POTATO	A6	POTATOES
7 PIZZA	A7	PIZZA
8 SOUP	A8	SOUP
9 OATS	A9	OATS

NOTE

After pressing the AUTO COOK button, auto cook functions can be scrolled by pressing the corresponding number pads until the same function is pressed twice.

Example:

1. Press AUTO COOK button
2. Press number pad “1” - display “A1”
3. Press number pad “5” - display “A5”
4. Press number pad “8” - display “A8”
5. Press number pad “3” - display “A3”
6. Press number pad “3” - display “150” (this step has confirmed to proceed with Auto Cook Fish function).
7. Continue to press number pad “3” until desired weight is chosen.
8. Press START / +30 SEC button to commence operation.

OPERATING YOUR BREVILLE PRODUCT

AUTO-MENU	WEIGHT (G)	PRESS	DISPLAY
A-1 Reheat	150	1 time	150
	250	2 times	250
	350	3 times	350
	400	4 times	400
A-2 Vegetables	150	1 time	150
	350	2 times	350
	500	3 times	500
A-3 Fish	150	1 time	150
	250	2 times	250
	350	3 times	350
	400	4 times	400
	450	5 times	450
A-4 Meat	150	1 time	150
	300	2 times	300
	450	3 times	450
	600	4 times	600
A-5 Pasta	50 (with cold water 450ml)	1 time	50
	100 (with cold water 800ml)	2 times	100
	150 (with cold water 1200ml)	3 times	150
A-6 Potatoes	1 (approx. 200g)	1 time	1
	2 (approx. 400g)	2 times	2
	3 (approx. 600g)	3 times	3
A-7 Pizza	1 (approx. 80g)	1 time	1
	2 (approx. 160g)	2 times	2
	3 (approx. 250g)	3 times	3
A-8 Soup	500	1 time	500
	750	2 times	750
	1000	3 times	1000
A-9 Oats	550	1 time	550
	1100	2 times	1100

TIPS ON AUTO MENU SETTINGS

Auto Reheat

Will calculate the time required to reheat food above 60 C. Place food in/on microwave safe containers and cover with microwave safe lid, vented cling film or absorbent paper.

Vegetables

When cooking vegetables, always cook them covered with a vented lid, cling wrap or absorbent paper. Wash vegetables and shake lightly, leaving some water clinging to it. Place into microwave safe bowl and cover.

Fish

Place fish fillets into a microwave safe dish, evenly spaced. Place dish onto a rack or inverted bowl. Cover with a microwave safe lid or vented cling film.

Meat

Place meat on a rack which sits inside a shallow dish or on a rack which contains its own run off rim around the edge. Cook fat-side up first and turn over halfway through cooking. If cooking mince or diced meat, place into a microwave safe round casserole dish and stir halfway through cooking.

Pasta

Choose a microwave safe bowl large enough to hold the corresponding amount of water. Make sure that the water comes up no higher than $\frac{3}{4}$ of the bowl. This prevents spillage or scolding from boiling water. Note that pasta will swell and double in size.

Potatoes

Prick each potato 3-4 times with a fork and arrange around the outer edges of turn table.

Pizza

Line turn table with absorbent paper. Place pizza slices directly on top. This will prevent crust from becoming soggy.

Soup

Choose a microwave safe bowl large enough to hold the corresponding amount of soup. Make sure that the soup comes up no higher than $\frac{3}{4}$ of the bowl. This prevents spillage or scolding from boiling liquid. Always stir soup halfway through cooking time.

Oats

Choose a microwave safe bowl large enough to hold the correct quantity. Make sure that the porridge comes up no higher than $\frac{3}{4}$ of the bowl. Note that porridge will swell and double in size.

MULTI-STAGE MICROWAVE COOKING

At most, 2 stages can be selected for cooking. In multi-stage cooking, if one stage is defrosting, then defrosting shall be placed in the first stage.

Example: If you want to cook the food with 100% power level for 10 minutes plus 80% microwave power for 15 minutes, Do it as following:

1. Press the POWER LEVEL button once to show "P100".
2. Press 1, 0, 0, 0, to set the cooking time.
3. Press the POWER LEVEL button twice to show "P 80".
4. Press 1, 5, 0, 0, to set the cooking time.
5. Press the START / +30 SEC button to start cooking.

SETTING THE DOOR SAFETY LOCK

The safety lock prevents unsupervised operation by young children. While in lock mode, the door can be opened, however the microwave cannot be turned on.

1. To set, press and hold STOP/CLEAR pad for 3 seconds. There will be a long 'beep' denoting unit is entering the children-lock state and a  will be displayed.
2. To unlock, press and hold STOP/CLEAR pad for 3 seconds, and there will be a long 'beep' denoting that the lock is released.

COOKING END REMINDING FUNCTION

When cooking ends, there will be 5 'beeps' which denotes completion of cooking.

DISPLAY SPECIFICATION

1. In waiting state, LED will display clock and ':' will flash.
2. In function setting state, LED will display the related setting.
3. In the operation and suspending state, LED will display the residual cooking time.

HINTS & TIPS

SOME IMPORTANT TIPS FOR MICROWAVE COOKING

To help equalize energy in the food so that it cooks evenly follow these helpful tips.

1. Arrange foods with varying size ends, such as chicken drumsticks and broccoli with the thicker or tougher part positioned to the outside of the dish. This ensures the parts that require more cooking will receive more energy, so the food will cook evenly.
2. Covering the dish during cooking holds in the heat and steam to speed up cooking time. Use a microwave safe lid or plastic wrap that has been vented by turning back one edge at the side of the dish to form a narrow vent to release excess steam.
3. Choose cooking dishes that are shallow and preferably have straight sides. Shallow dishes enable the food to cook faster and straight edges prevent the edges from being overcooked.
4. Arrange individual items such as ramekins or whole potatoes around the outside of the turntable. Making sure to leave space between items so the energy can penetrate from all sides.
5. Use round shaped microwave dishes. Round shapes cook more evenly than square or rectangle dishes which absorb most of the energy in the corners causing food to overcook and toughen.
6. Shield areas which attract the most energy such as wing tips of chickens and corners of square dishes by covering them with small pieces of foil. This will reflect microwaves and prevent overcooking and food drying out.
7. Heat breads, biscuits or oily food on paper towel. This prevents the build up of steam between food and carousel, keeping surfaces crisp and dry. Cover foods with paper toweling to prevent splatters.
8. Stir foods from the outside to centre of the dish once or twice during cooking to equalize heat and speed microwaving.
9. Turn medium to large food items over once during microwaving. This enables even exposure to microwaves.
10. Elevating some types of food such as cakes, roast vegetables and dough products can be advantageous. It allows more energy to penetrate the food from all sides, base and top. Use a microwave safe plastic or ceramic rack. If a rack is unavailable, use an upturned bowl or cup may be used to elevate plates of food.
11. Do not elevate any special browning dishes, jugs of sauce or custard, small quantities of food or mugs of beverages.
12. Internal temperatures of foods continue to rise so that they continue cooking even after they have been removed from the microwave oven. It is better to undercook food as it will continue to cook once removed from the microwave.

MICROWAVE UTENSILS

- Containers, plates, dishes, etc. used in the microwave oven should always be microwave-safe. Check if stated on the underside of the utensil or contact the manufacturer.
- To test if a container, plate or dish is microwave-safe, place it into the microwave oven with 1 cup of cold water (in a microwave-safe cup) and heat on High (100%) Power for 1 minute. If the container is hot and the water is cold, the container is not suitable for microwave oven use. If the container is cold and the water is hot, then the container is suitable for microwave oven use.
- Metal containers and utensils should not be used in the microwave oven.

CARE & CLEANING

for your Breville product

CARE & CLEANING

- Switch off the microwave oven at the power outlet and remove the plug from the power outlet before cleaning.
- Keep the inside of the microwave oven clean. When food splatters or spilled liquids adhere to the microwave oven internal walls, wipe with a damp cloth. Mild detergent may be used if the cavity gets very dirty. Avoid the use of spray and other harsh cleaners as they may stain, streak or dull the door surface.
- The outside surfaces should be cleaned with a damp cloth. To prevent damage to the operating parts inside the microwave oven cavity, water should not be allowed to seep into the ventilation openings.
- Wipe the door and window on both sides of the door seals and adjacent parts frequently with a damp cloth to remove any spills or spatters. Do not use an abrasive cleaner.
- Do not allow the control panel to become wet. Clean with a soft, damp cloth. When cleaning the control panel, leave the microwave oven door open to prevent it from accidentally turning on.
- If steam accumulates inside or around the outside of the oven door, wipe with a soft dry cloth. This may occur when cooking foods high in moisture or if the microwave oven is operated under high humidity conditions, this is normal.
- It is occasionally necessary to remove the glass turntable for cleaning. Wash the turntable in warm soapy water, rinse in clean water and dry thoroughly.
- The roller ring and microwave oven floor should be cleaned regularly to ensure the glass turntable rotates correctly and avoids making excessive noise. Simply wipe the bottom surface of the microwave with a soft damp cloth. The roller ring may be washed in mild soapy water, rinse in clean water and dry thoroughly. When removing the roller ring from the cavity floor for cleaning, be sure to replace in the proper position.
- Remove odours from your microwave oven by combining a cup of water with the juice of one lemon in a deep microwave-safe bowl, microwave on High PL10 for 5 minutes. Wipe the microwave oven cavity thoroughly and dry with a soft cloth.
- When it becomes necessary to replace the oven light, please consult your Breville Service Centre to have it replaced.
- Please do not dispose this appliance with domestic rubbish; it should be taken to the appropriate disposal centre provided by the local council municipalities.
- If storing the microwave oven, press the STOP/CANCEL button, switch off at the power outlet then unplug the power cord. Ensure the microwave oven is completely cool, clean and dry. Secure the roller ring and glass turntable and close the door. Do not place heavy objects on top. Store the microwave oven upright.

BEFORE YOU CALL FOR SERVICE

- Check to ensure that the oven is plugged in securely. If it is not, remove the plug from the power outlet, wait 10 seconds and plug it in again securely.
- Check for a blown circuit fuse or a tripped main circuit breaker. If these seem to be operating properly, test the power outlet with another appliance.
- Check to ensure that the control panel is programmed correctly and the timer is set.
- Check to ensure that the door is securely closed engaging the door safety lock system. Otherwise, the microwave energy will not flow into the oven.

NOTE

If none of the above rectify the situation, then contact your Breville Service Centre. Do NOT try to adjust or repair the oven yourself.

TROUBLESHOOTING

TROUBLESHOOTING

POSSIBLE PROBLEM	EASY SOLUTION	
Microwave oven interfering with television reception.	<ul style="list-style-type: none"> • Radio and TV reception may be interfered with during operation. This is similar to the interference that is sometimes cause by vacuums, blenders etc. 	
Dim microwave oven light.	<ul style="list-style-type: none"> • When operating on low power levels, the microwave oven light may be dimmer. 	
Steam accumulating on door and hot air coming out from vents.	<ul style="list-style-type: none"> • During operation, steam may be produced. Most will exit through the vents, however some may accumulate around the oven door. 	
POSSIBLE PROBLEM	POSSIBLE REASON	EASY SOLUTION
Microwave oven will not start.	<ul style="list-style-type: none"> • Power cord not plugged in properly or switched on. • Fuse blown or circuit breaker problem. • Trouble with outlet. 	<ul style="list-style-type: none"> • Unplug, put the plug in again and switch on. • Replace the fuse or reset circuit breaker. • Have a professional check that the outlet is not faulty.
Microwave oven does not heat.	<ul style="list-style-type: none"> • Door not closed properly. 	<ul style="list-style-type: none"> • Ensure door is shut properly.
Glass turntable makes noise during operation.	<ul style="list-style-type: none"> • Roller not assembled properly or needs to be cleaned. 	<ul style="list-style-type: none"> • Reset and clean if necessary.

RECIPES

INDIAN SPICED TOMATO CHUTNEY

Makes 2 cups

INGREDIENTS

- ½ cup vegetable oil
- 2cm piece ginger, finely shredded
- 4 cloves garlic, crushed
- 2 long red chillies, chopped
- 1 large red onion, chopped
- 1 tablespoon black mustard seeds
- 1 tablespoon ground turmeric
- 1 tablespoon ground cumin
- 2 sprigs fresh curry leaves, leaves only
- 3 teaspoons salt
- 1 cup white sugar
- ½ cup malt vinegar
- 1kg chopped ripe tomatoes

METHOD

1. Place oil, ginger, garlic, chilli and onion into a large heat-proof microwave-safe bowl and Press POWER LEVEL button once for 100% and select 2 minutes cook time. Press START/+30 SEC button.
2. Remove from microwave and stir in remaining ingredients. Press POWER LEVEL button once for 100% and select 40–50 minutes cook time. Press START/+30 SEC button, stirring every 10 minutes until chutney has reduced and thickened.
3. Spoon into sterilized jars and cool completely before storing in the refrigerator.

Serve with BBQ meats or cold on sandwiches.

CHUNKY MINESTRONE

Serves 6

INGREDIENTS

- 1 onion, chopped
- 2 cloves garlic, crushed
- 3 bacon rasher, chopped
- 1 carrots, diced
- 1 stick celery, diced
- ¼ small cabbage, shredded
- 750ml tomato passata
- 3 cups water or stock
- 400g can three bean mixed, drained and rinsed
- ½ cup small pasta such as penne, macaroni or fusili
- Salt and freshly ground white pepper
- ¼ cup chopped fresh basil

METHOD

1. Place onion, garlic and bacon into a large 3 litre heat proof microwave safe bowl. Press POWER LEVEL button once for 100% and select 2 minutes cook time. Press START/+30 SEC button.
2. Add carrots, celery, cabbage, passata, stock, beans and pasta and Press POWER LEVEL button once for 100% and select 15 minutes cook time. Press START/+30 SEC button. Cook stirring every 10 minutes until vegetables and pasta are tender.
3. Season with salt and pepper and stir through chopped basil. Ladle into large bowls and serve with crusty bread.

FETTUCCHINE BOSCAIOLA

Serves 4

INGREDIENTS

500g fettuccine
 40g butter
 1 clove garlic, crushed
 200g button mushrooms, trimmed and sliced
 150g middle cut bacon, rind removed and chopped
 1 cup cream
 ¼ cup freshly grated Parmesan
 Salt and freshly ground black pepper

METHOD

1. Cook fettuccine in a large saucepan of boiling salted water according to packet instructions. Drain and set aside.
2. Place butter, garlic, mushrooms and bacon into a large heat-proof microwave-safe bowl and Press POWER LEVEL button once for 100% and select 2 minutes cook time. Press START/+30 SEC button.
3. Stir and add cream; return to microwave and Press POWER LEVEL button twice for 80% and select 5 minutes cook time. Press START/+30 SEC button. Stir in half the Parmesan and toss through hot fettuccine. Season to taste with salt and pepper.

Serve topped with extra Parmesan.

FAMILY MICROWAVE MEATLOAF

Serves 4–6

INGREDIENTS

800g beef mince
 100g middle bacon, finely chopped
 2 tablespoons tomato sauce
 1 tablespoon Worcestershire sauce
 1 carrot, grated
 2 cloves garlic, crushed
 ½ cup dry breadcrumbs
 1 egg, beaten
 ½ cup BBQ sauce

METHOD

1. Combine beef, bacon, sauces, carrot, garlic, breadcrumbs and egg together in a large bowl until thoroughly mixed.
2. Spoon BBQ sauce into the base of a heat-proof microwave-safe loaf dish and pack meat into dish, pushing down gently to compact the meatloaf. Place meatloaf in microwave, elevated on a microwave-safe rack.
3. Press POWER LEVEL button once for 100% and select 10 minutes cook time. Press START/+30 SEC button.
4. Reduce power level by pressing Press POWER LEVEL button three times for 50% and select 7–10 minutes cook time. Press START/+30 SEC button.
5. Allow meatloaf to stand for 10 minutes in loaf dish before unmolding and slicing.

Serve either warm with hot potatoes or cold in wraps or sandwiches.

CHICKEN CACCIATORE

Serves 4

INGREDIENTS

8 small chicken drumsticks
 1 tablespoon olive oil
 ¼ cup drained sundried tomatoes
 1 tablespoon chopped fresh herbs such as oregano, basil and thyme
 ½ cup drained slice black olives
 700ml tomato passata

METHOD

1. Place chicken drumstick into a shallow heat-proof microwave-safe casserole dish making sure to position the thick end to the outside of the dish. Add remaining ingredients and toss to coat.
2. Place a sheet of baking paper over the top and cover with 2 layers of cling film, making sure to leave a 5cm vent for steam to escape.
3. Elevate baking dish by placing dish on a microwave-safe rack.
4. Press POWER LEVEL button twice for 80% and select 15 minutes cook time. Press START/+30 SEC button.
5. Stand 10 minutes and check drumsticks to make sure they are cooked through. If still a little pink, return to microwave and cook a further 5 minutes.

Serve hot with rice or pasta.

CHOCOLATE WALNUT BROWNIES

Serve 6–8

INGREDIENTS

200g dark 70% cooking chocolate, chopped
 125g butter, diced
 1 teaspoon vanilla extract
 2 eggs, lightly beaten
 ½ cup caster sugar
 ½ cup light muscovado sugar or light brown sugar
 ¾ cup plain flour
 ¼ cup self-raising flour
 ½ teaspoon baking powder
 ¼ cup cocoa powder
 1 cup chopped walnuts

METHOD

1. Place chocolate and butter into a large heat-proof microwave-safe bowl and press START/=+30 button once. Stir and repeat until butter has melted and chocolate has softened but not completely melted. Stir mixture until smooth and well combined.
2. Beat in vanilla, eggs and sugars until well mixed.
3. Sift flours, baking powder and cocoa together and fold through chocolate mixture. Pour into a square 20cm x 20cm heat-proof microwave safe Pyrex dish lined with baking paper.
4. Smooth the surface with a spatula and sprinkle over the walnuts. Lightly push down walnuts into brownie. Elevate baking dish by placing dish on a microwave-safe rack.
5. Press POWER LEVEL button three times for 80% and select 8–10 minutes cook time. Press START/+30 SEC button.
6. Cook until just cooked through; centre will still be soft. Remove and cool in dish completely before refrigerating until cold.

HOME MADE CITRUS CURD

Makes 2 cups

INGREDIENTS

3 eggs
 2 egg yolks
 ¼ cup caster sugar
 2 lemons, zest of 1
 1 lime
 1 navel orange
 125g butter, diced

METHOD

1. Combine eggs, egg yolks, sugar and lemon zest in a large heat-proof microwave- safe bowl. Whisk until well combined.
2. Juice lemons, lime and orange to make up ¾ cup of combined juice and add to egg and sugar mixture.
3. Press POWER LEVEL button three times for 50% and select 8 minutes cook time. Press START/+30 SEC button.
4. Cook, stirring every 1-2 minutes until thickened and just boiling. Remove and cool and pour into sterilized.

FIG AND PEACH JAM

Makes 2 cups

INGREDIENTS

700g ripe peaches
 300g fresh figs, peeled and chopped
 1½ cups caster sugar
 2 lemons, juiced

METHOD

1. Cut a small cross into the base of each peach. Place into a large bowl and pour over boiling water; stand 5 minutes or until skin begins to lift off. Peel, remove seed and chop flesh.
2. Place chopped peach into a 3 litre heat-proof microwave-safe bowl along with figs, sugar and lemon juice and mix well.
3. Press POWER LEVEL button once for 100% and select 5 minutes cook time. Press START/+30 SEC button.
4. Stir well until sugar has dissolved and return to microwave. Press POWER LEVEL button once for 100% and select 40 minutes cook time. Press START/+30 SEC button.
5. Stir jam every 8-10 minutes until fruit has reduced and jam consistency. Spoon into sterilized jars and seal. Cool completely.

CARROT CAKE

Serves 10–12

INGREDIENTS

- 2 eggs
- ½ cup light olive oil
- ½ cup milk
- 1½ cups caster sugar
- 1 ½ cups self raising flour
- 1 teaspoons grand cinnamon
- ½ teaspoon bicarbonate soda
- ½ cup canned crushed pineapple in natural juice, drained well
- 1½ cups (approx 2 medium) carrots, grated
- ⅔ cup chopped walnuts

CREAM CHEESE FROSTING

- 30g butter, softened
- 125g cream cheese, softened
- ½ teaspoon vanilla extract
- 1 ½ cups icing sugar, sifted

METHOD

1. Whisk together eggs, oil, milk and sugar and set aside.
2. Add the flour, cinnamon, soda and fold through until mixture is just combined.
3. Add carrots, drained pineapple and walnuts. Pour mixture into a greased heat-proof microwave-safe 22cm ring pan.
4. Elevate cake pan by placing dish on a microwave-safe rack.
5. Press POWER LEVEL button three times for 50% and select 15–20 minutes cook time. Press START/+30 SEC button.
6. Stand cake for 10 minutes and check that cake is cooked with a skewer. Remove from pan and cool completely on a cake rack. If cake has moist spots on the surface; place absorbent paper on top during standing time.
7. To make frosting: Using an electric mixer beat butter, cheese and vanilla on a medium speed for about 1–2 minutes or until well combined.
8. Reduce speed and add sugar; once added increase speed again until mixed well.
9. Spread on cooled cake.

