

the Oracle™ Touch

SES990



EN QUICK GUIDE

Sage®



Contents

2	Sage® Recommends Safety First
5	Components
7	Functions
10	Care & Cleaning
14	Troubleshooting
18	Guarantee

SAGE® RECOMMENDS SAFETY FIRST

At Sage® we are very safety conscious. We design and manufacture appliances with your safety foremost in mind. We also ask that you exercise a degree of care when using any electrical appliance and adhere to the following precautions.

IMPORTANT SAFEGUARDS

READ ALL INSTRUCTIONS BEFORE USE AND SAVE FOR FUTURE REFERENCE

- A downloadable version of this document is also available at sageappliances.com
- Before using for the first time, please ensure that your electricity supply is the same as shown on the rating label on the underside of the appliance. If you have any concerns, please contact your local electricity company.

- The installation of a residual current safety switch is recommended to provide additional safety when using all electrical appliances. Safety switches with a rated operating current not more than 30mA are recommended. Consult an electrician for professional advice.
- Remove and discard any packaging materials safely, before first use.
- To eliminate a choking hazard for young children, discard the protective cover fitted to the power plug safely.
- Ensure the product is properly assembled before first use.
- This appliance is for household use only. Do not use the appliance for anything other than its intended purpose. Do not use in moving vehicles or boats. Do not use outdoors. Misuse may cause injury.
- Position the appliance on a stable, heat resistant, level, dry surface away from the counter edge, and do not operate on or near a heat source such as a hot plate, oven or gas hob.
- Fully unwind the power cord before operating.
- Do not let the power cord hang over the edge of a counter or table. Do not let the power cord touch hot surfaces or become knotted.
- Do not leave the appliance unattended when in use.

- If the appliance is to be:
 - left unattended
 - cleaned
 - moved
 - assembled; or
 - stored

Always switch off the espresso machine by pressing the POWER button to OFF. Switch off and unplug from the power outlet.

- Regularly inspect the power cord, plug and actual appliance for any damage. If found to be damaged in any way, immediately cease use of the appliance and return the entire appliance to the nearest authorised Sage Service Centre for examination, replacement or repair.
- Keep the appliance and accessories clean. Follow the cleaning instructions provided in this book. Any procedure not listed in this instruction booklet should be performed at an authorised Sage Service Centre.
- The appliance can be used by children aged 8 years or older and persons with reduced physical, sensory or mental capabilities or a lack of experience and knowledge, only if they have been given supervision or instruction concerning use of the appliance in a safe way and understand the hazards involved.
- Children should not play with the appliance.
- Cleaning of the appliance should not be carried out by children unless they are 8 years or older and under adult supervision.
- The appliance and its cord should be kept out of reach of children aged 8 years and younger.
- Do not use attachments other than those provided with the appliance.
- Do not attempt to operate the appliance by any method other than those described in this booklet.
- Do not move the appliance whilst in operation
- Do not use any other liquid apart from cold mains/town water. We do not recommend the use of highly filtered, de-mineralised or distilled water as this may affect the taste of the coffee and how the espresso machine is designed to function.
- Never use the appliance without water in the water tank.
- Ensure the portafilter is firmly inserted and secured into the brewing head before using the machine.
- Never remove the portafilter during the brewing operation as the machine is under pressure.
- Do not place anything, other than cups for warming, on top of the appliance.
- Use caution when operating machine as metal surfaces are liable to get hot during use.

- Do not touch hot surfaces. Allow the product to cool down before moving or cleaning any parts.
- Heating element surface is subject to residual heat after use.
- Use caution after milk texturing as the 'Auto Purge' function may purge hot steam when the steam wand is lowered.
- Use caution when using the de-scale feature as hot steam may be released. Before de-scaling, ensure drip tray is empty and inserted. Refer to page 13 for further instructions.
- Do not operate the grinder without the hopper lid in position. Keep fingers, hands, hair, clothing and utensils away from the hopper during operation.

SPECIFIC INSTRUCTIONS FOR WATER FILTER

- Filter cartridge should be kept out of reach of children.
- Store filter cartridges in a dry place in the original packaging.
- Protect cartridges from heat and direct sunlight.
- Do not use damaged filter cartridges.
- Do not open filter cartridges.
- If you are absent for a prolonged period of time, empty the water tank and replace the cartridge.



The symbol shown indicates that this appliance should not be disposed of in normal household waste.

It should be taken to a local authority waste collection centre designated for this purpose or to a dealer providing this service. For more information, please contact your local council office.



To protect against electric shock, do not immerse the power cord, power plug or appliance in water or any other liquid.

FOR HOUSEHOLD USE ONLY SAVE THESE INSTRUCTIONS



Components

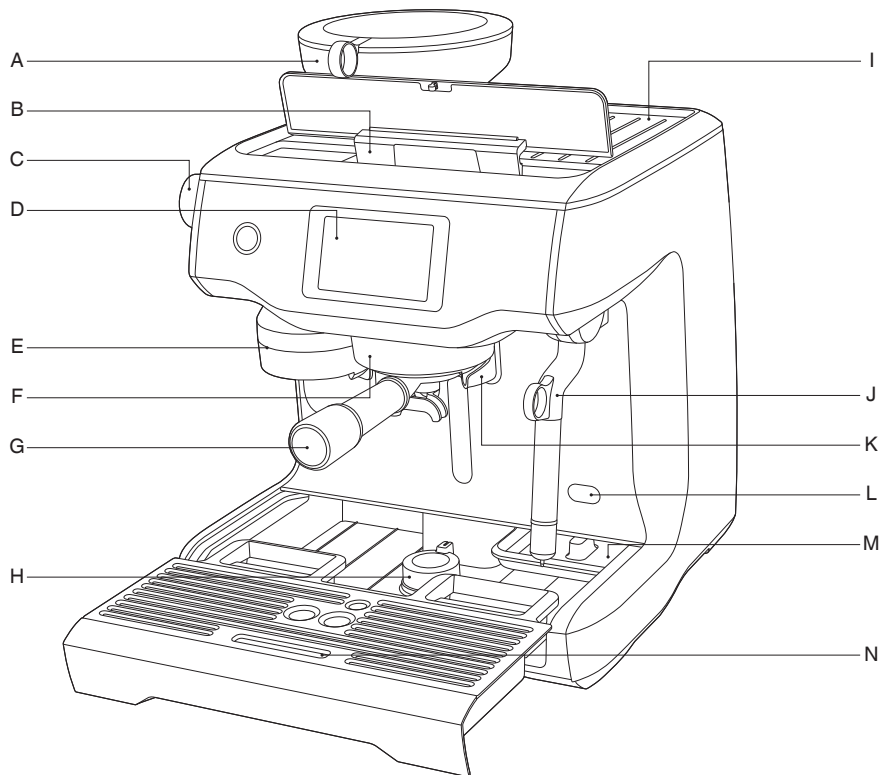

- | | |
|---------------------------------------|-------------------------------|
| A. Integrated conical burr grinder | I. Heated cup warming tray |
| B. Top-fill 2.5L removable water tank | J. Cool touch steam wand |
| C. Grind size dial | K. Dedicated hot water outlet |
| D. Touch screen control panel | L. Descale access point |
| E. Grind outlet | M. Tool storage tray |
| F. 58mm group head | N. Removable drip tray |
| G. 58mm stainless steel portafilter | |
| H. Drop down swivel foot | |



Rating Information

220-240V~50-60Hz 2000-2400W

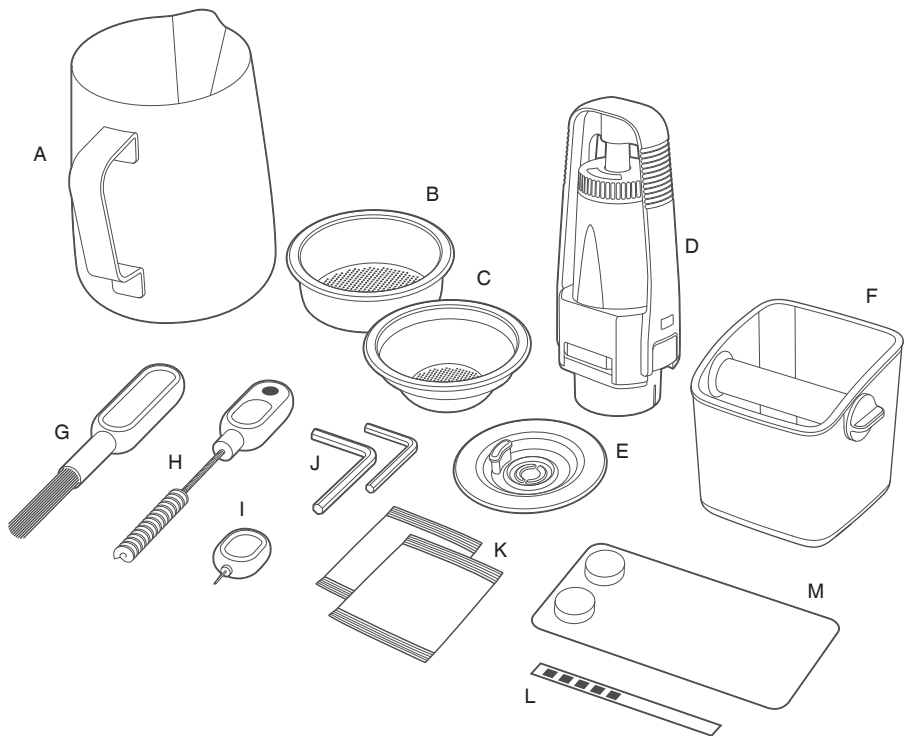

ACCESSORIES

- A. Stainless steel milk jug
- B. 2 cup filter basket
- C. 1 cup filter basket
- D. Water filter holder with filter
- E. Cleaning disc
- F. Mini grinds bin
- G. Grinder burr brush
- H. Grind outlet brush & tamp removal magnet
- I. Cleaning tool for steam wand tip
- J. Two allen keys
- K. Steam wand cleaning powder
- L. Water hardness test strip
- M. Espresso cleaning tablets



Functions

INSTALLING THE WATER FILTER

- Soak the filter in cold water for 5 minutes.
- Wash the filter holder with cold water.

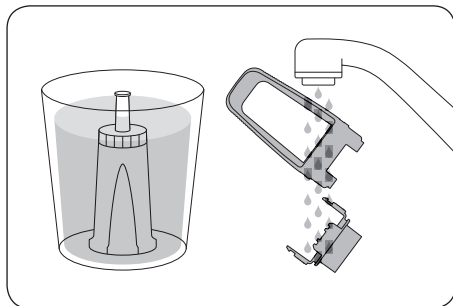

- Set the reminder for next month of replacement. We recommend to replace the filter after 3 months.

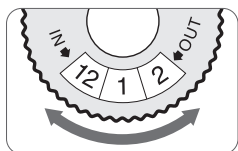

- Insert the filter into the two parts of the filter holder.

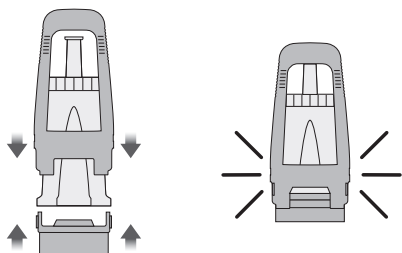

- To install the assembled filter holder into the water tank, align the base of the filter holder with the adapter inside the water tank. Push down to lock into place.

- Fill the water tank with cold water, slide and lock back into position.

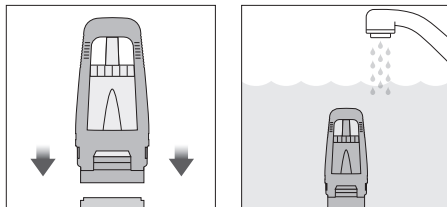

FIRST USE

1. Press **POWER** button to turn the machine on.
2. Follow the instructions on screen to guide you through first use setup.
3. After completing setup, the machine will tell that it is ready to use.

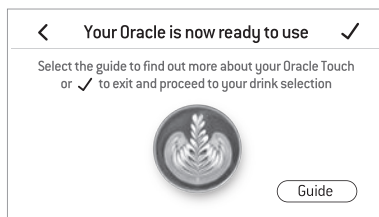

The machine is now in **STANDBY** mode.



NOTE

If your water hardness is either 4 or 5 when tested, we strongly recommend you change to an alternate water source.

GRINDING OPERATION

Insert bean hopper into position on-top of the machine. Turn dial to lock into place. Fill hopper with fresh beans.

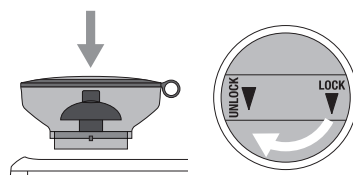

DRINK SELECTION

To enter Drinks Menu screen, touch the Home icon . Swipe & select your drink. Touch the 'Help & Tip' icon  to see Oracle™ Touch Guide.



NOTE

Please keep the touch screen dry and clean to ensure that the machine functions properly.

DRINK SCREEN

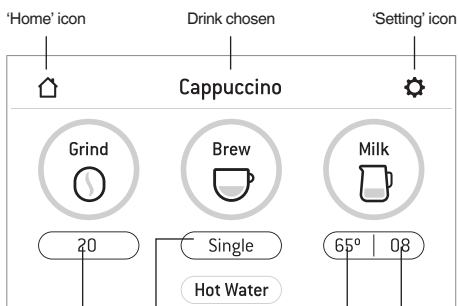

Grind size
Adjust using the dial on the side of the machine

Brew setting: touch this button to scroll
Espresso – single shot / double shot / custom extraction time
Long Black – small / medium / large

Milk froth level
Milk temperature

SELECTING GRIND SIZE

There are 45 grind size settings (No.1 – finest, No. 45 – coarsest).

We recommend you start at No. 30 and adjust – finer if extraction is too fast, coarser if too slow. Espresso should start to flow within 8–12 seconds.

SELECTING YOUR FILTER BASKET

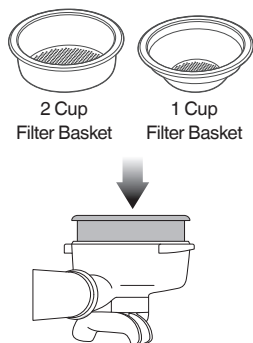

AUTO GRIND DOSE & TAMP

Align portafilter handle with the INSERT position on the grind outlet. Lift to insert portafilter into the grind outlet and rotate to the centre position.

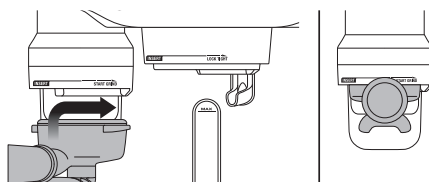

To start the auto grind, dose & tamp function, touch the 'Grind' button on the display. Grinding will commence.

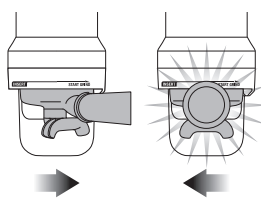

When the auto grind, dose & tamp function is complete, rotate the portafilter handle to the INSERT position and lower to remove.

ESPRESSO EXTRACTION

Align portafilter handle with the INSERT position on the group head. Lift to insert portafilter into the group head and rotate towards the LOCK TIGHT position until resistance is felt.

Press 'Brew' button on the display to start extraction. You can change the shot volume.

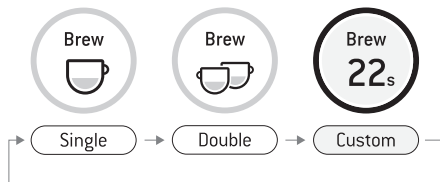

MANUAL OVERRIDE

Press and hold the 'Brew' button (approx 2 secs) to enter manual extraction mode. Touch the 'Brew' button to start the extraction, touch the 'Brew' button to stop the extraction.

AUTO TEXTURING MILK

Start with fresh cold milk. Fill milk jug to below the spout position. Lift steam wand and insert into milk jug. Lower steam wand, ensuring it is fully down. The milk jug should rest on the drip tray and milk should cover the steam wand seal.

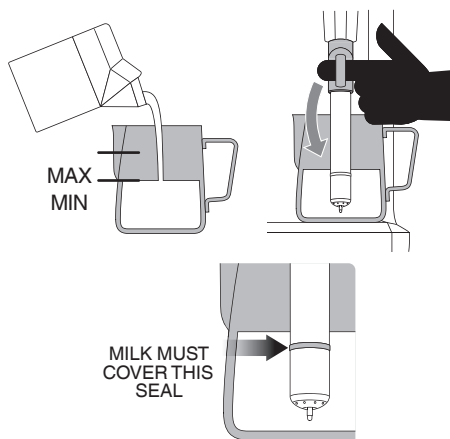

To start, touch the 'Milk' button. The screen will display the temperature of the milk as it heats. Milk texturing will stop automatically when the selected milk temperature is reached. Lift steam wand to remove milk jug. **Wipe the wand & tip with a clean damp cloth.** Lower steam wand to the down position and the wand will automatically purge.

MANUAL MILK TEXTURING

Auto milk texturing and auto shut-off are disabled during manual milk texturing mode. Lift the steam wand. Start frothing by touching the button. When frothing is done, touch the Milk button to stop.

Wipe the wand & tip with a clean damp cloth. Lower steam wand to the down position and the wand will automatically purge.



CAUTION: BURN HAZARD

Pressurised steam can still be released, even after machine has been switched off.

Children must always be supervised.

AMERICANO

There are 3 preset Americano settings – small, medium and large.

Grind dose & tamp your porta-filter & insert into the group head. Position your cup underneath the porta-filter spouts & the hot water spout. Espresso will be extracted first, the hot water is delivered automatically after the espresso.

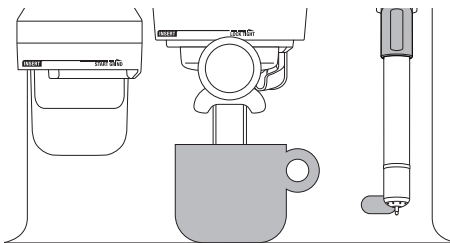

PRESET CUP SIZE

AMOUNT BREWED

Small	Approx. 6oz / 180ml
Medium	Approx. 8oz / 240ml
Large	Approx. 12oz / 360ml

CAFÉ CREMA

There are 3 presets for the Café Crema setting, Small (120ml), Medium (150ml), Large (180ml). Insert the single cup filter basket, adjust grinder to a coarse setting as prompted on screen.

HOT WATER

The HOT WATER function can be used to pre-heat cups or add hot water manually.

To start & stop hot water, touch 'Hot Water' on the screen.

ADDING NEW DRINK

Touch 'Create New' in the menu screen to create a customised drink. You can adjust parameters based on a standard style and save your own.



Add New

Alternatively, after manually adjusting parameters touch the small icon  to save the current setting.

SETTINGS

To enter settings menu, touch the icon  on the upper right on the screen.

TRANSPORTING AND STORING

We recommend draining both boilers completely before transporting the machine or storing for an extended period of time. Refer to the Descale section for the step by step instructions.

This procedure is also intended as an anti-freeze measure in the event the machine is exposed to extreme cold temperatures.

AUTO OFF MODE

The machine automatically switches to AUTO OFF mode after 30 minutes.



Care & Cleaning

COLOUR TOUCH SCREEN DISPLAY

Please keep the touch screen dry and clean to ensure that the machine functions properly.

CLEANING CYCLE

- A message for cleaning will be displayed to indicate when a cleaning cycle is required (approx. 200 shots). Or you can start cleaning cycle by choosing 'Clean Cycle' in 'Settings'. The cleaning cycle cleans the shower screen and back-flushes the group head.
- Follow the instruction on the touch screen.

INSTALLING THE WATER FILTER

Refer to page 7.

CLEANING CONICAL BURRS

Regular cleaning helps the burrs achieve consistent grinding results which is especially important when grinding for espresso.

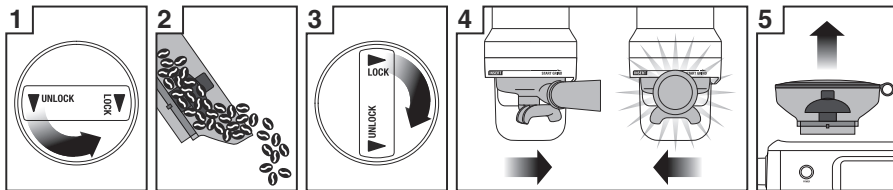

1 Unlock hopper

2 Remove beans

3 Replace & lock hopper

4 Run grinder until empty

5 Unlock & remove hopper

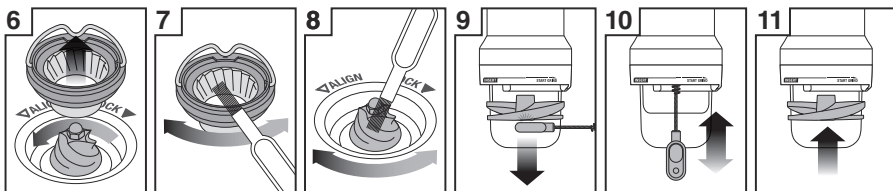

6 Remove upper burr

7 Clean upper burr with burr brush

8 Clean lower burr with burr brush

9 Remove tamping fan with tamp removal magnet

10 Clean grind outlet with grind outlet brush

11 Replace tamping fan by hand

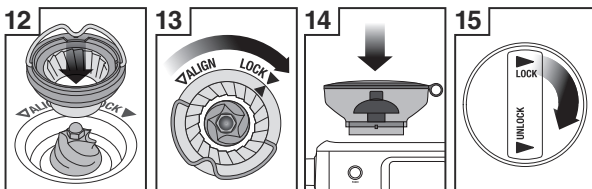

12 Push upper burr firmly into position

13 Lock upper burr

14 Insert hopper

15 Lock hopper

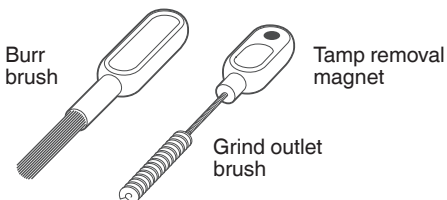

Burr brush

Tamp removal magnet

Grind outlet brush

CLEANING THE STEAM WAND



IMPORTANT

After every use, thoroughly wipe the steam wand and tip with a damp cloth & purge immediately. Failure to clean the steam wand may affect the milk texturing performance.

- If any of the holes in the tip of the steam wand become blocked, ensure the machine stopped steaming and unblock using the steam tip cleaning tool.
- If steam wand remains blocked, remove the tip and soak together with steam wand using the provided steam wand cleaning powder (instructions below). Screw tip back onto the steam wand after rinsing.

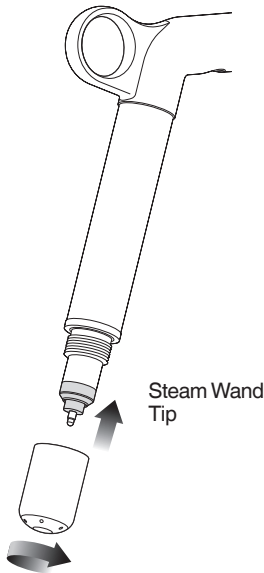

- The steam wand can be left immersed in the milk jug filled with water when not in use to reduce the risk of blockages.

Steam Wand Cleaning Powder

1. Add 1 packet into an empty milk jug.
2. Add 1 cup (8oz/240ml) hot water into milk jug.
3. Remove steam tip and place with steam wand into jug.
4. Leave to soak for 20 minutes.

5. Clean, rinse and replace steam tip. Place wand back into the jug and activate steam for 10 seconds.
6. Allow to soak for 5 minutes.
7. Activate steam several times to purge the steam wand, then rinse the wand thoroughly.
8. Wipe the steam wand dry with a clean cloth.
9. Discard solution & rinse jug thoroughly.



NOTE

Please ensure the steam wand tip is tightly fastened after cleaning to avoid temp sensing error.

CLEANING THE FILTER BASKET AND PORTAFILTER

- The filter basket and portafilter should be rinsed under hot water after each coffee making session to remove all residual coffee oils.
- If the holes in the filter basket become blocked, dissolve a cleaning tablet in hot water and soak filter basket and portafilter in solution for approx. 20 minutes. Rinse thoroughly.

CLEAR WATER BACKFLUSH

- After each coffee making session we recommend doing a clear water backflush before you turn off the machine. Empty drip tray. Insert the cleaning disc into the filter basket then insert the portafilter into the group head. Touch the 'Brew' button and allow pressure to build for 20 seconds, then touch to stop & release pressure. Repeat this 5 times to purge any fine coffee grounds and residual coffee oils from the brew water paths.

CLEANING THE SHOWER SCREEN

- The group head interior and shower screen should be wiped with a damp cloth to remove any ground coffee particles.
- Periodically, run hot water through the group head with the filter basket and portafilter in place, but without ground coffee. This will remove any residual ground coffee particles from the shower screen.
- If there seems to be stubborn build up on the shower screen, use the allen key to undo the screw in the middle of the shower screen, making note of which side faces into the group head.

CLEANING THE DRIP TRAY & STORAGE TRAY

- The drip tray should be removed, emptied and cleaned after each use.
- Remove grill from the drip tray. Wash the drip tray in warm soapy water.
- The storage tray can be removed and cleaned with a soft, damp cloth (do not use abrasive cleansers, pads or cloths which can scratch the surface).

CLEANING THE OUTER HOUSING & CUP WARMING TRAY

- The outer housing and cup warming tray can be cleaned with a soft, damp cloth. Polish with a soft, dry cloth. Do not use abrasive cleansers, pads or cloths which can scratch the surface.



NOTE

Do not clean any of the parts or accessories in the dishwasher.

DESCALE

- Use this function to access the descale procedure when promoted on screen.
- The machine will enter descale mode if you choose to descale from the pop-up message or if you choose 'Settings' > 'Descal Cycle'. Follow the instruction on the touch screen.
- Please ensure you allow approximately 1.5 hours to complete the entire descale process and follow the step by step instructions.
If you've just finished using your machine, please ensure to turn the machine off and allow to cool for at least 1 hour before starting your descale process.



NOTE

DO NOT attempt to descale your machine without using the Descale procedure in the Settings menu. Damage to your machine could occur.



Troubleshooting

PROBLEM	POSSIBLE CAUSE	WHAT TO DO
Grinder Motor starts but no ground coffee coming from grind outlet	<ul style="list-style-type: none">• No coffee beans in bean hopper.• Grinder/bean hopper is blocked.• Coffee bean may have become stuck in hopper.	<ul style="list-style-type: none">• Fill bean hopper with fresh coffee beans.• Remove bean hopper. Inspect bean hopper & grinding burrs for blockage. Replace parts and try again.
Grinder Motor starts but operates with a loud 'clicking' noise	<ul style="list-style-type: none">• Grinder is blocked with foreign item or chute is blocked.• Moisture clogging grinder.	<ul style="list-style-type: none">• Remove bean hopper, inspect burrs and remove any foreign body.• Clean the burrs and grind outlet, see page 11.• Leave burrs to dry thoroughly before re-assembling. It is possible to use a hair dryer to blow air into the burr area to quicken the drying process.
Unable to lock bean hopper into position	<ul style="list-style-type: none">• Coffee beans obstructing bean hopper locking device.	<ul style="list-style-type: none">• Remove bean hopper. Clear coffee beans from top of burrs. Re-lock bean hopper into position.
Portafilter overfills	<ul style="list-style-type: none">• Tamping fan was removed for cleaning and not replaced.	<ul style="list-style-type: none">• Check that the tamping fan is in position and mounted correctly to the drive shaft, see Instruction Book on Sage website.
Grinder Emergency stop?		<ul style="list-style-type: none">• Rotate the portafilter to the left to stop the auto grind, dose & tamp function.• Unplug power cord from power outlet.
Grinder running continuously	<ul style="list-style-type: none">• No beans in hopper.	<ul style="list-style-type: none">• Fill hopper with beans.• Rotate the portafilter to the left to stop the auto grind, dose & tamp function.
	<ul style="list-style-type: none">• Tamping fan has been removed.	<ul style="list-style-type: none">• Check that the tamping fan is in position and mounted correctly to the drive shaft, see Instruction Book on Sage website.

PROBLEM	POSSIBLE CAUSE	WHAT TO DO
Espresso runs out around the edge of the portafilter	<ul style="list-style-type: none"> • Portafilter not inserted in the group head correctly. 	<ul style="list-style-type: none"> • Ensure portafilter is rotated to the right until the handle is past the centre and is securely locked in place. Rotating past the centre will not damage the silicone seal.
and/or	<ul style="list-style-type: none"> • There are coffee grounds around the filter basket rim. 	<ul style="list-style-type: none"> • Clean excess coffee from the rim of the filter basket after grinding to ensure a proper seal in group head.
Portafilter comes out of the group head during an extraction	<ul style="list-style-type: none"> • Filter basket rim is wet or underside of portafilter lugs are wet. Wet surfaces reduce the friction required to hold the portafilter in place whilst under pressure during an extraction. 	<ul style="list-style-type: none"> • Always ensure filter basket and portafilter are dried thoroughly before filling with coffee, tamping and inserting into the group head.
Issues with the Auto Start feature	<ul style="list-style-type: none"> • Clock not set or clock is set with incorrect time. 	<ul style="list-style-type: none"> • Check that the clock and Auto Start time have been programmed correctly.
Operation Error message on the touch screen	<ul style="list-style-type: none"> • A major fault has occurred and machine cannot operate. 	<ul style="list-style-type: none"> • Contact Sage Customer Service Centre.
Pumps continue to operate / Steam is very wet / Hot water outlet leaks	<ul style="list-style-type: none"> • Using highly filtered, demineralised or distilled water which is affecting how the machine is designed to function. 	<ul style="list-style-type: none"> • We recommend using cold, filtered water. We do not recommend using water with no/low mineral content such as highly filtered, demineralised or distilled water. If the problem persists, contact Sage Consumer Support.
Water does not flow from the group head	<ul style="list-style-type: none"> • Machine has not reached operating temperature. 	<ul style="list-style-type: none"> • Allow time for the machine to reach operating temperature.
	<ul style="list-style-type: none"> • Water tank is empty. 	<ul style="list-style-type: none"> • Fill tank. Prime the system by: <ol style="list-style-type: none"> 1) Touching the 'Brew' button to run water through the group head for 30 seconds. 2) Touching 'Hot Water' to run water through the hot water outlet for 30 seconds.
	<ul style="list-style-type: none"> • Water tank not fully inserted & locked. 	<ul style="list-style-type: none"> • Push water tank in fully and lock latch closed.

PROBLEM	POSSIBLE CAUSE	WHAT TO DO
Display says “Water tank empty” but water tank is full	<ul style="list-style-type: none"> • Water tank not fully inserted & locked. 	<ul style="list-style-type: none"> • Push water tank in fully and lock latch closed.
No steam or hot water	<ul style="list-style-type: none"> • Machine is not turned on or up to operating temperature. 	<ul style="list-style-type: none"> • Ensure the machine is plugged in and ready for use. • You may have a blockage in scale. Please run the descale process.
No hot water	<ul style="list-style-type: none"> • Water tank is empty. 	<ul style="list-style-type: none"> • Fill water tank.
No steam	<ul style="list-style-type: none"> • Steam wand is blocked. 	<ul style="list-style-type: none"> • Refer to ‘Cleaning the Steam Wand’, page 12. • You may have a blockage in scale. Please run the descale process.
The machine is ‘On’ but won’t operate		<ul style="list-style-type: none"> • Turn machine off. Wait for 60 minutes and turn machine back on. • If problem persists, call Sage Consumer Support.
Steam pouring out of group head		<ul style="list-style-type: none"> • Turn machine off. Wait for 60 minutes and turn machine back on. • If problem persists, call Sage Consumer Support.
Espresso only drips from the portafilter spouts, restricted flow	<ul style="list-style-type: none"> • Coffee is ground too finely. 	<ul style="list-style-type: none"> • Adjust the grind size to a higher number to make the grind size slightly coarser. • You may have a blockage in scale. Please run the descale process.
Espresso flows out too quickly	<ul style="list-style-type: none"> • The coffee is ground too coarsely. • Coffee beans are stale. 	<ul style="list-style-type: none"> • Adjust the grind size to a lower number to make the grind size slightly finer. • Use freshly roasted coffee beans with a ‘Roasted On’ date and consume between 5–20 days after that date.
Coffee not hot enough	<ul style="list-style-type: none"> • Cups not pre-heated. <hr/> <ul style="list-style-type: none"> • Milk not hot enough (if making cappuccino or latté etc). 	<ul style="list-style-type: none"> • Rinse cups under hot water outlet and place on cup warming tray. <hr/> <ul style="list-style-type: none"> • Increase the milk temperature in settings menu.
No crema	<ul style="list-style-type: none"> • Coffee beans are stale. 	<ul style="list-style-type: none"> • Use freshly roasted coffee beans with a ‘Roasted On’ date and consume between 5–20 days after that date.

PROBLEM	POSSIBLE CAUSE	WHAT TO DO
Not enough milk texture	<ul style="list-style-type: none"> • Steam wand is blocked. 	<ul style="list-style-type: none"> • Refer to 'Cleaning the Steam Wand', page 12. • You may have a blockage in scale. Please run the descale process. <hr/> <ul style="list-style-type: none"> • Different brands and types of milk and milk alternatives will texture differently. You may need to adjust the froth level accordingly.
Too much coffee extracted	<ul style="list-style-type: none"> • Coffee is ground too coarsely. • Shot duration/volume needs to be adjusted. 	<ul style="list-style-type: none"> • Adjust the grind size to a lower number to make the grind size slightly finer. • Customise extraction time by touching the 'Single' / 'Double' button.
Not enough coffee extracted	<ul style="list-style-type: none"> • Coffee is ground too finely. • Shot duration/volume needs to be adjusted. 	<ul style="list-style-type: none"> • Adjust the grind size to a higher number to make the grind size slightly coarser. • Customise extraction time by touching the 'Single' / 'Double' button.
Amount of coffee extracted has changed, but all settings are the same.	<ul style="list-style-type: none"> • As coffee beans age, the extraction rate changes and can affect the shot volume. 	<ul style="list-style-type: none"> • Adjust the grind size to a lower number to make the grind size slightly finer. • Customise extraction time by touching the 'Single' / 'Double' button. • Use freshly roasted coffee beans with a 'Roasted On' date and consume between 5–20 days after that date.



Guarantee

2 YEAR LIMITED GUARANTEE

Sage Appliances guarantees this product for domestic use in specified territories for 2 years from the date of purchase against defects caused by faulty workmanship and materials. During this guarantee period Sage Appliances will repair, replace, or refund any defective product (at the sole discretion of Sage Appliances).

All legal warranty rights under applicable national legislation will be respected and will not be impaired by our guarantee. For full terms and conditions on the guarantee, as well as instructions on how to make a claim, please visit www.sageappliances.com.



Notes

GBR

IRE

BRG Appliances Limited
Unit 3.2, Power Road Studios, 114 Power Road, London, W4 5PY
Freephone (UK Landline): +44 (0)808 178 1650
Mobile Calls (National Rate): 0333 0142 970

Sage[®]

www.sageappliances.com

Registered in England & Wales No. 8223512.

• Due to continued product improvement, the products illustrated or photographed in this document may vary slightly from the actual product.
Copyright BRG Appliances 2019.

BES990 UG1 E19